



**FABCO TC-237  
TRANSFER CASE  
SERVICE MANUAL**

## TABLE OF CONTENTS

<b>Introduction and Specifications</b>	<b>3</b>
<b>Front View</b>	<b>4</b>
<b>Rear View</b>	<b>5</b>
<b>Lubrication – Types and Inspection</b>	<b>6</b>
<b>Cleaning and Inspection, End-float Explanation</b>	<b>8</b>
<b>General Instructions, Assembly Precautions</b>	<b>9</b>
<b>Removal and Installation</b>	<b>10</b>
<b>General Disassembly</b>	<b>11</b>
<b>Disassembly of the Sub-assemblies</b>	<b>17</b>
<b>Input Shaft Assembly</b>	<b>19</b>
<b>Intermediate Shaft Assembly</b>	<b>21</b>
<b>Rear-output Shaft Assembly</b>	<b>22</b>
<b>Front-output Shaft Assembly</b>	<b>22</b>
<b>General Assembly</b>	<b>24</b>
<b>Torque Specifications</b>	<b>32</b>
<b>Parts Identification</b>	<b>33</b>
<b>Parts Listings</b>	<b>35</b>
<b>Tooling</b>	<b>40</b>

# **TC - 237 TRANSFER CASE**

## **• INTRODUCTION**

The Fabco TC-237 two-speed transfer case is designed for use in all wheel drive vehicles. The transfer case provides drive to the front axle(s) and can be used in any configuration of rear driven axles. The front drive axle can be engaged at any vehicle speed, provided the rear wheels are not spinning; however, the vehicle must be stationary before the shift can be made between high and low ranges, otherwise serious damage may occur. The shifting between ranges and the engagement of front drive and power take-off clutches is accomplished by air-operated cylinders.

## **• SPECIFICATIONS**

The TC-237 transfer case is a two-speed, three-shaft, constant-mesh design featuring a declutch for the front axle and underdrive engagement.

### **NOMINAL RATING**

Input Torque	6,000 Lb. Ft.
Input Horsepower	300 HP
Input Speed	3,200 RPM

### **RATIOS**

High	1:1
Low	2.22:1

### **GEAR TYPE**

Helical High Range and Spur Low Range

### **SHAFT SIZES**

Input & Rear Output	1.95 Inches, 38 Involute Spline
Front Output	2.25 Inches, 10 Parallel Spline

### **SHAFT SPACING (Drop)**

12.00 Inches to Rear Output  
12.00 Inches to Front Output

### **SHIFT MECHANISM**

Integral Air Cylinders

### **BEARINGS**

Tapered Roller

### **LUBRICATION**

Splash

### **LUBRICANT**

See Page 6

### **OIL CAPACITY**

6.5 Quarts (U.S.)

### **DRY WEIGHT**

360 Lbs.

### **HOUSING**

Aluminum

### **OPTIONS**

Full Power PTO, Mechanical Range Shift

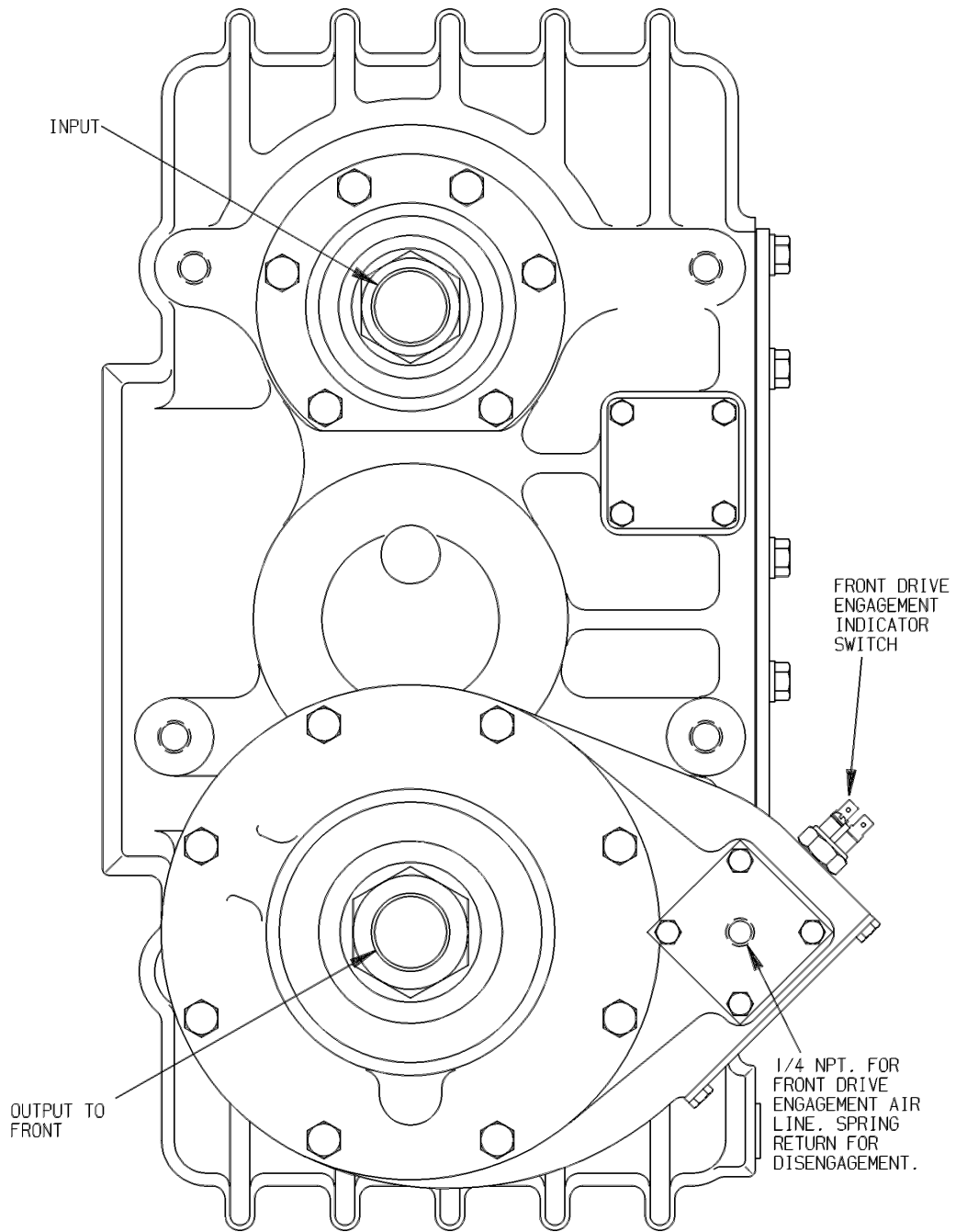

**FRONT VIEW - FABCO TC-237 TRANSFER CASE**

**REAR VIEW - FABCO TC-237 TRANSFER CASE**

## **LUBRICATION**

### **• RECOMMENDED LUBRICANTS**

On-Highway Vehicles

#### 1. Heavy Duty Engine Oil:

<u>Temperature</u>	<u>Grade</u>
Above + 10 F	SAE 50
Below + 10 F	SAE 30

Be sure to specify heavy-duty type meeting MIL-L-2104B specifications.

#### 2. Mineral Gear Oil:

<u>Temperature</u>	<u>Grade</u>
Above + 10 F	SAE 90
Below + 10 F	SAE 80

Must be inhibited against corrosion, oxidation, and foam.

### **• OFF-HIGHWAY & MINING EQUIPMENT**

#### 1. Heavy-Duty Engine Oil:

<u>Temperature</u>	<u>Grade</u>
Above + 10 F	SAE 50
Below + 10 F	SAE 30

Be sure to specify heavy-duty type, meeting MIL-L-2104B specifications.

2. Special Recommendation: For extreme cold weather where temperature is consistently below 0 F, use SAE 20W heavy-duty engine oil meeting MIL-L-2104B specifications.

**NOTE:** EXTREME PRESSURE (EP) OILS ARE NO LONGER RECOMMENDED FOR USE IN FABCO TRANSFER CASES. UNDER CERTAIN OPERATING CONDITIONS THESE OILS MIGHT FORM CARBON DEPOSITS ON GEARS, SHAFTS, AND BEARINGS.

### **• INSPECTION**

The oil is to be maintained at the level of the fill plug at all times. Check at the following intervals:

Highway Service.....1,000 Miles

Off -Highway Service..... 40 Hours

With every oil change, the shift cylinder air lines and valves should be inspected for leaks and possible malfunctioning. Low-pressure conditions can cause partial clutch engagement, which may result in premature wear or damage.

### **• OIL CHANGE**

The transfer case lubricant should be changed on all new transfer cases after the first 3,000 to 5,000 miles (on-highway), or the first 40 hours (off-highway); thereafter oil changes should be done at the following intervals:

On-Highway Service.....10,000-15,000 Miles

Off-Highway Service  
(Logging, dirt moving,  
mining, and associated  
operations).....500-750 Hours

The recommended oil change and inspection periods are based on the average use and operating conditions that the unit may encounter. It is suggested that the individual owner make a periodic lab analysis of the lubricant to determine contamination based on the unit's specific operating conditions. With this data, the oil change and inspection periods can be better determined.

### **• DRAINING THE OIL**

Draining is best accomplished after the vehicle has been operated briefly, allowing the oil to become warm and flow more freely. Remove both drain and fill plugs. Allow the housing to empty completely. Before the unit is refilled, it should be thoroughly flushed with clean flushing oil or kerosene.

- **REFILLING THE OIL**

If the transfer case has been removed from the vehicle for service, it is best to refill the oil after the unit has been reinstalled into the vehicle.

Clean and replace the drain plug and fill the transfer case with the appropriate oil with the vehicle on level ground. Fill the transfer case to the level of the fill plug. The plug should be installed only after the oil level has stabilized.

For each transfer case the oil capacity will vary somewhat, depending on the model and the inclination of the unit; therefore, always fill to the level of the fill plug. Do not overfill. Inspect for leaks.

- **OPERATING TEMPERATURE**

The operating temperature of the transfer case should not exceed 250 F (120 C). Extensive operation at temperatures exceeding 250 F will result in rapid breakdown of the oil and may shorten the transfer case life.

The following conditions may contribute to excessive oil temperature.

1. A vehicle remaining stationary for extended periods while operating the power take-off.
2. A vehicle which is used in tropical or desert conditions.
3. A vehicle where extended bodywork or an accumulation of dirt and plant material may shield the case from air ventilation and circulation.
4. A vehicle that is operated for extended distances at high speed with the main transmission in overdrive.

## **CLEANING AND INSPECTION**

### **• CLEANING**

Steam may be used for external cleaning of completely assembled units. Care must be taken to ensure that water is kept out of the assembly by sealing breather caps and other openings.

The transfer case parts that are too large to conveniently clean with solvents, may be immersed in a hot solution tank containing a mild alkaline solution. Aluminum parts such as the carriers, caps, declutch housings, air shift cylinder components, and aluminum case housings must never be cleaned in any type of alkaline solution. Parts cleaned in a hot solution tank must be rinsed thoroughly to prevent damage by traces of alkaline material.

Parts with ground or polished surfaces, such as bearings, gears, shafts, and oil pump components should be cleaned with emulsion cleaners or petroleum solvents. An alkaline solution may damage the machined surfaces and such cleaning methods should be avoided.

### **• DRYING AND CORROSION INHIBITION**

Dry parts with compressed air or clean, soft shop towels should be used to dry parts after cleaning. Bearings should never be spun dry with compressed air.

Dried parts should be immediately coated with a light oil or corrosion inhibitor to prevent corrosion damage. Parts that are to be stored should also be wrapped in heavy waxed paper or plastic bags and kept dust-free.

### **• INSPECTION**

Prior to reassembly, parts that are to be reused must be carefully inspected for signs of wear or damage. Replacement of such parts can prevent costly downtime at a future date.

All bearing surfaces, including roller bearing cups and cones, should be examined for pitting, wear, or overheating. Gears may also show pits, as well as scoring and broken teeth. Shafts may be nicked or marred, or have damaged threads. Parts that show any sign of damage should be repaired or replaced.

Inspect the internal parts of the oil pump (if equipped) for scoring. Any damaged parts should be replaced.

Check all shift forks and grooves in sliding clutches for wear or discoloration due to heat. Check the engaging teeth for a partial engagement wear pattern.

### **• END-FLOAT MEASUREMENTS**

End-float measurements given in this service manual refer to the specifications as **tight** or **loose**. While a **loose** measurement can be taken directly as read from a dial indicator, a **tight** one cannot.

**Tight** end-float measurements can only be obtained mathematically through a measurement that was previously **loose**.

Ex. – If an intermediate shaft end-float measurement of .005 inches **loose** is found, a .002 inches **tight** end-float measurement can be obtained by removing .007 inches of shims from behind the bearing cup.

If the previous example's measurement were taken after the shims were removed, it would have shown an end-float measurement of .000 inches, which is incorrect.

Therefore, if a measurement of .000 inches is obtained, it is best to disassemble the part, add a shim of minimal thickness, and re-measure. Using this method will alleviate any end-float measurements that may be overly tight.

## **GENERAL INSTRUCTIONS**

### **• SAFETY**

The servicing and maintenance of components from any automotive vehicle present possible hazards; every endeavor should be made to minimize the risks taken to successfully complete the task. For your protection, we offer these warnings and suggestions.

1. When working on, around, or under the vehicle, the parking brake should be securely applied and all wheels should be blocked to prevent wheel movement. Do not rely on the vehicle being in gear with a dead engine to prevent movement. All work should be performed on a flat level surface free of loose material.
2. When working under a vehicle, it should be raised and supported with the appropriate frame stands or very secure blocking.

 **WARNING:** NEVER WORK UNDER A VEHICLE WHILE SUPPORTED ONLY ON A FLOOR JACK OR HOIST.

3. Be sure any lifting equipment has adequate capacity to raise the vehicle or component being lifted. This includes hydraulic floor jacks, crane type hoists, transmission jacks, and axle support dollies, etc. The weight of Fabco components is given in the front of the applicable service manual.
4. Caution must be exercised when cleaning the component or underside of the vehicle. Compressed air should not be used to blow dirt away as any harmful contaminant material on the bottom of the vehicle will be spread around the work area.

Appropriate solvents and cleaning solutions can be used in accordance with their labeling instructions or by referring to the Material Safety Data sheet (MSDS) that is available for each cleaner. Approved protective eyewear, gloves, masks and clothing should always be worn.

### **• ASSEMBLY PRECAUTIONS**

1. Read the instructions completely before starting reassembly. Refer to the appropriate exploded view in the parts manual.
2. All parts must be clean. The gasket surfaces must be free of old gasket material. Do not reuse old gaskets.
3. Bearing cup bores, shaft splines and bearing mounting surfaces, should be coated with Lubriplate or equivalent. This is necessary to reduce the possibility of galling.
4. All used oil seals must be replaced and the new oil seals should be coated with Loctite 601 or equivalent on their outer diameter prior to being installed in their bores. The sealing lips should be coated with Lubriplate or the equivalent to provide initial lubrication.
5. Unless otherwise specified, any external cap screw, not installed in a blind hole, should have its threads coated with Permatex Form-A-Gasket #2 or an equivalent non-hardening sealer to prevent an oil leak.
6. All threaded fasteners should be tightened to the torque specified in the torque chart.
7. Any sharp edges on the seal diameter of the universal joint yoke or companion flanges should be removed with emery cloth and should be coated with Lubriplate or the equivalent on the seal operating area prior to installation.
8. In many of the procedures, when a part is assembled with a press fit, it is recommended that the part be heated prior to installation. The part should be placed in an oven and heated to no more than 300 F. Excessive heat may change the metallurgical properties of the part. Heated components should be allowed to cool to room temperature before end-float measurements are made.

 **CAUTION:** ALTHOUGH FABCO DOES NOT RECOMMEND ITS USE IN TRANSFER CASES, IF FORMED-IN-PLACE GASKET IS USED FOR REPAIRS, EXTREME CAUTION MUST BE EXERCISED TO PREVENT THE COMPOUND FROM ENTERING BEARINGS, OIL GALLERIES, AND PASSAGES. ALL BEADS MUST BE KEPT SMALLER THAN 1/8 INCH DIAMETER.

## **REMOVAL & INSTALLATION**

### **• REMOVAL**

1. Remove fill and lower drain plugs and drain gear lubricant.
2. Disconnect wires leading to indicator light switch and temperature sensor, if used.
3. Disconnect and tag shift cylinder air lines.
4. Disconnect speedometer cable.
5. Disconnect drivelines at flanges or yokes.
6. Position a transmission jack of suitable capacity beneath the transfer case. The transfer case must be seated on the jack in a safe and firm position.
7. Disconnect transfer case mountings at the rubber shock insulators. Since mounting designs vary; consult the vehicle service manual.
8. After making sure that all mountings and connections to the transfer case are disconnected lower the transfer case gradually to the floor. It is imperative that the transfer case is ALWAYS safely positioned on the transmission jack to safeguard the transfer case from falling off the jack. Remove the transfer case from beneath the vehicle. It may be necessary to jack the truck up to allow room to remove transfer case.

### **• INSTALLATION INTO THE VEHICLE**

1. Place the transfer case onto a transmission jack.
2. Position the transmission jack underneath the vehicle. Some vehicles may require that one side be jacked up in order to achieve sufficient clearance to place the transfer case between the frame rails.
3. Raise the transmission jack to properly locate the transfer case.
4. Connect the transfer case mountings. Since mounting designs vary; consult vehicle service manual.
5. Connect the drivelines.
6. Connect the speedometer cable.
7. Connect the shift cylinder air lines.
8. Connect the indicator light and temperature sensor wires.
9. Fill the housing with the appropriate lubricant to the correct level and install the level plug.
10. Check the transfer case for leaks around the gaskets and seals.

## **NOTES**

## **DISASSEMBLY**

Disassembly and assembly of the Fabco TC-237 transfer case is a relatively simple procedure that can be made easier by the use of some very simple tooling. Details of all tooling are given in the tooling section for manufacture in your own facilities or Fabco Automotive may be contacted for price and availability of all special tools listed throughout this manual.

### **• GENERAL DISASSEMBLY**

1. The transfer case should be drained, cleaned and dried, and removed from vehicle.
2. The case may be disassembled on a clean workbench or floor as long as it is supported securely.
3. Remove the side access cover from the case. See Fig. 1.



Fig. 1

4. Remove and discard safety wire from the high-low shift shaft bolts and then remove bolts using a double square socket. See Figs. 2 and 3.



Fig. 2



Fig. 3

5. Remove the high-low shift cylinder cap bolts. Then remove the cylinder cap and cylinder sleeve by sliding them off the piston. See Fig. 4.



Fig. 4

6. While holding the shift shaft piston, lightly tap shift forks toward front of case to free them from the shift shaft.  
See Fig 5.

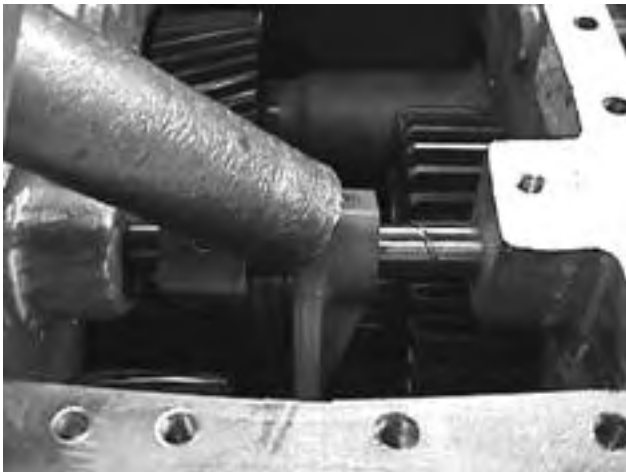

Fig. 5

7. Lightly file the shift shaft to remove the indentations left by the set-screws. This will prevent damage to the case and make the forks and shaft easier to remove.  
See Fig 6.

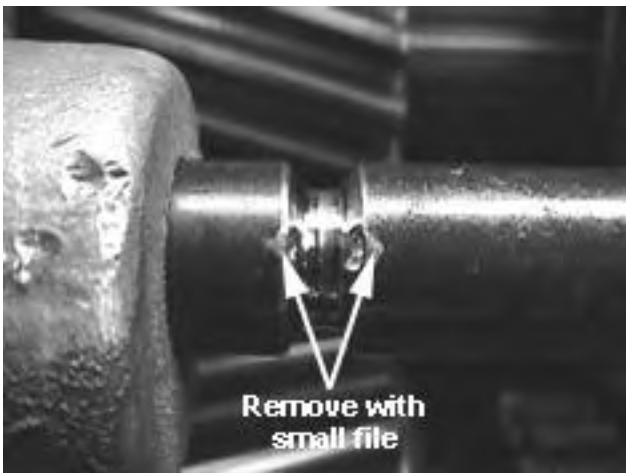

Fig. 6

8. Remove the shift shaft along with the piston, spring, and nylon stop ring, Similar to Fig. 9. If needed the shift cylinder adapter may also be removed from the case.  
See Fig 7.



Fig. 7

9. Remove shift forks from case.  
10. Remove the front declutch cover plate.  
See Fig. 8

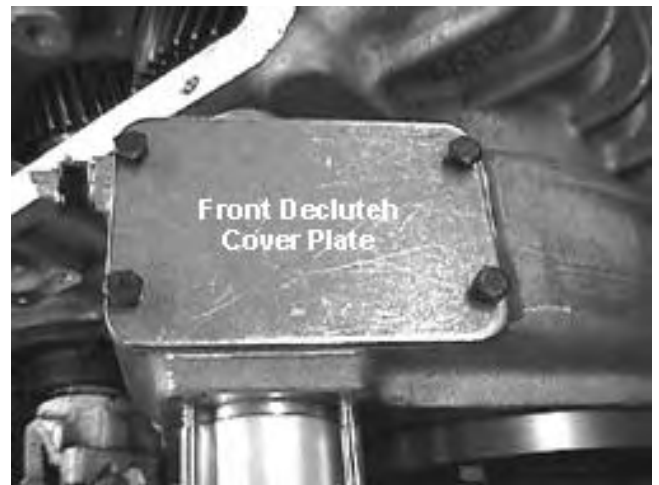

Fig. 8

11. Remove the front declutch shift cylinder bolts then remove the cap and cylinder.  
12. If necessary, remove the declutch shift piston from the shift shaft. See Fig. 9.

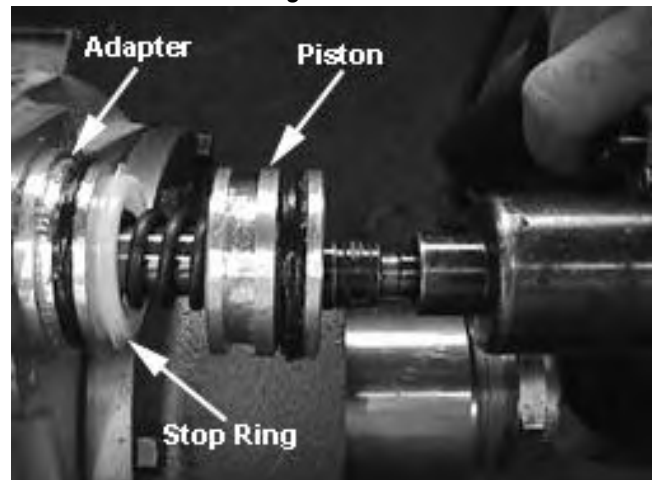

Fig. 9

13. Remove and discard the safety wire from the front declutch shift fork bolts. Be careful not to drop the wire into the housing.
14. Remove the declutch shift fork bolts followed by the front output carrier bolts. Remove the front output carrier from the housing.  
See Fig. 10.

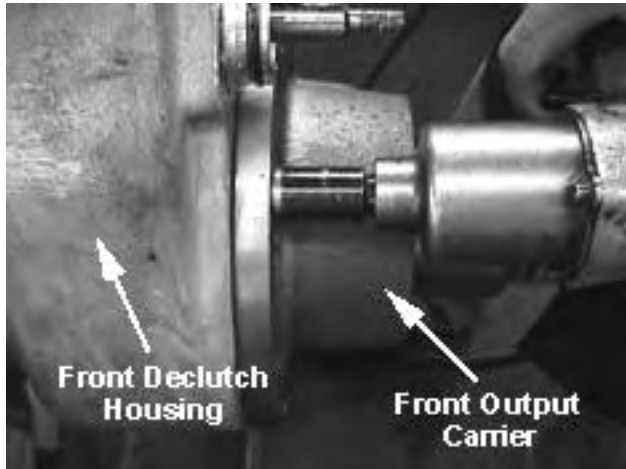

Fig. 10

15. Remove the shift shaft from housing followed by the declutch fork and collar.  
See Fig. 11.

**Note:** It is not necessary to remove the declutch housing to disassemble the case.

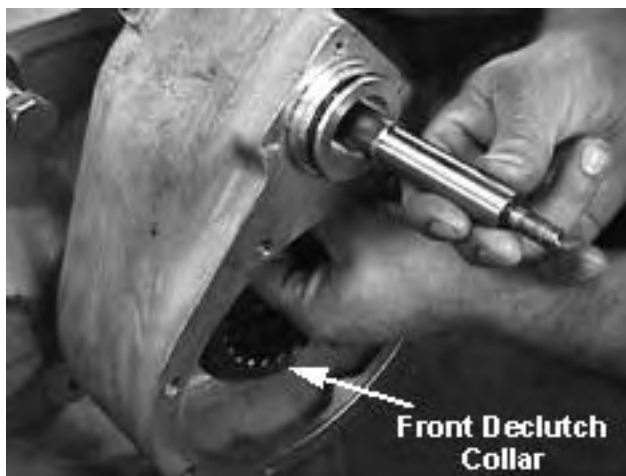

Fig. 11

16. Remove the yoke and rear-output shaft spacer from the rear output shaft.  
See Fig. 12.



Fig. 12

17. Remove the rear carrier.  
See Fig. 13.

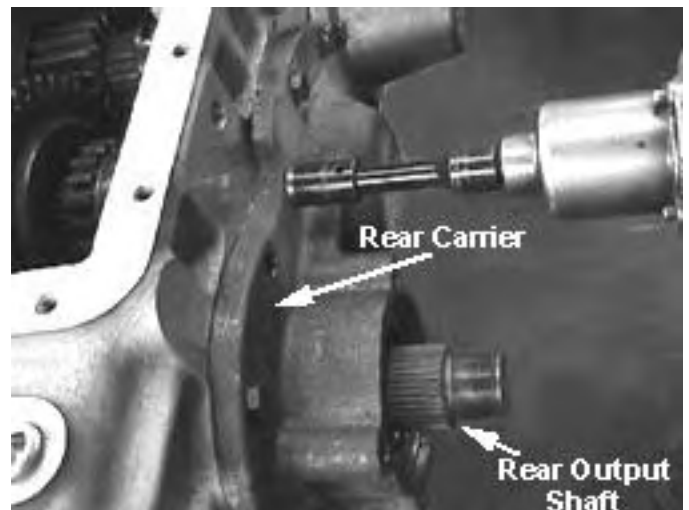

Fig. 13

18. Remove the rear-bearing lock nut from the intermediate shaft using the special socket # 866-0687-002.  
See Fig. 14.

**Note:** It may be necessary to warm the nut slightly to soften the locking compound applied to the threads.

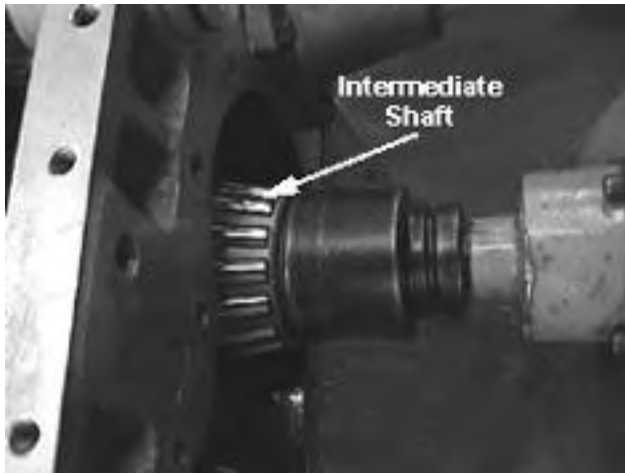

Fig. 14

19. Remove the input shaft rear cap from housing.  
See Fig. 15.

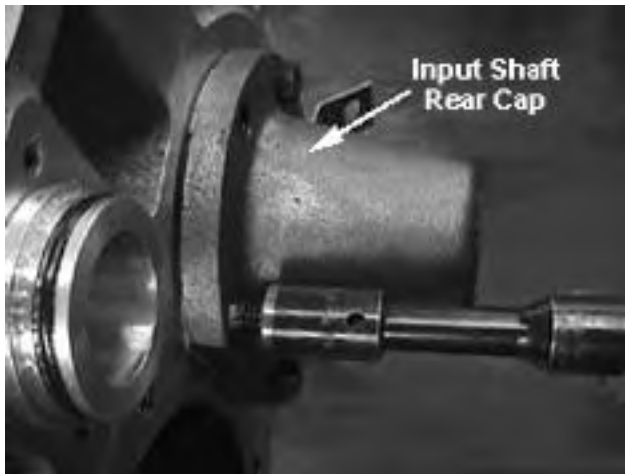

Fig. 15

20. Remove the bearing locknut from the rear of the input shaft using the special socket #866-0687-002. It may be helpful to engage both the high and low range drive clutches to lock the input and intermediate shafts together.

**Note:** It may be necessary to warm the nut slightly to soften the locking compound applied to the threads.

21. Remove the input yoke and seal carrier from the housing.  
See Fig. 16.

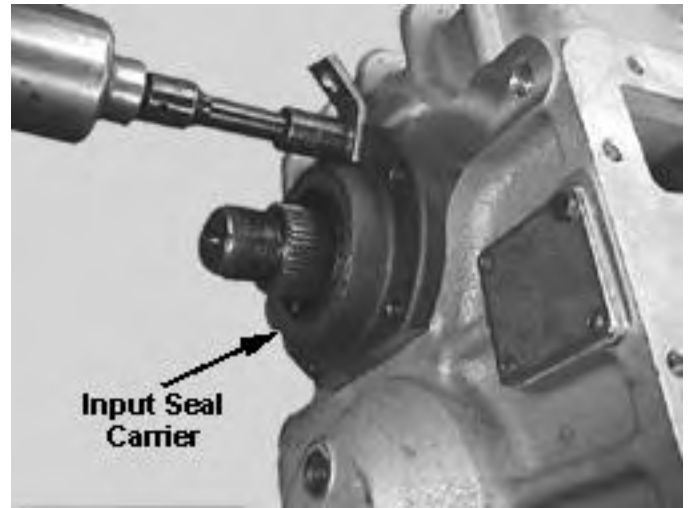

Fig. 16

22. Using a piece of brass or other soft material, lightly tap the input shaft toward the front of the case to drive out the front bearing cup.  
See Figs. 17 and 18.

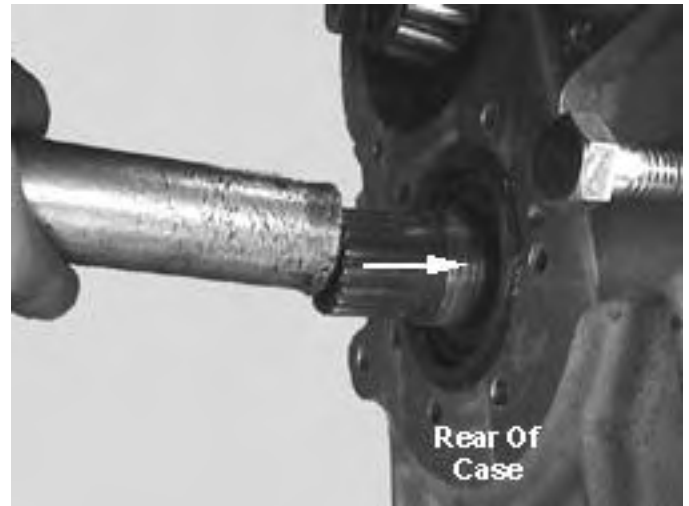

Fig. 17



Fig. 18

23. Slide the input shaft to the front of the case using a piece of wood in between the gear and the case to support the direct drive gear.  
See Fig. 19.



Fig. 19

24. Using a large brass drift and a hammer, drive the input shaft forward forcing the direct-drive gear and rear bearing off the shaft. Be careful not to let the input shaft fall to the floor.  
See Fig. 20.



Fig. 20

25. Remove bearing, direct-drive gear, and clutch gear while sliding the input shaft out the front of the case.  
See Fig. 21.



Fig. 21

26. Slide the intermediate shaft toward the rear of the housing as far as possible to facilitate the removal of the direct-drive gear.  
See Fig. 22.

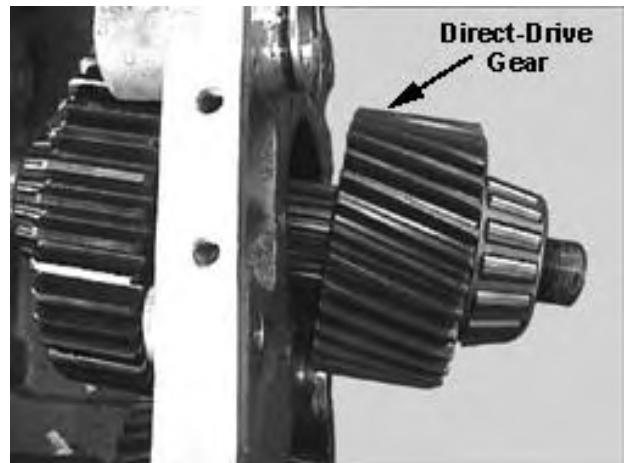

Fig. 22

27. Using a gear puller or similar tool, remove the direct-drive gear from the intermediate shaft.  
See Fig. 23.

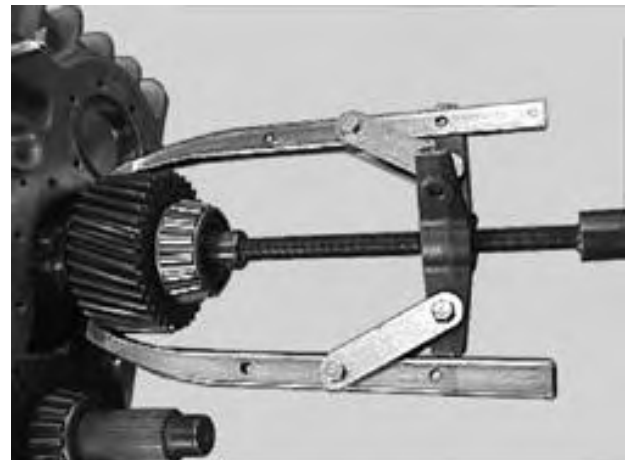

Fig. 23

28. Remove intermediate shaft from the housing.  
See Fig. 24.

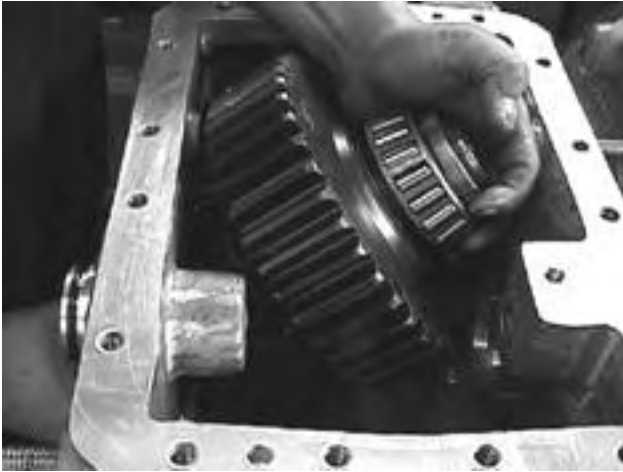

Fig. 24

29. Remove the rear output shaft from the case by sliding it through the rear carrier opening.  
See Fig. 25.

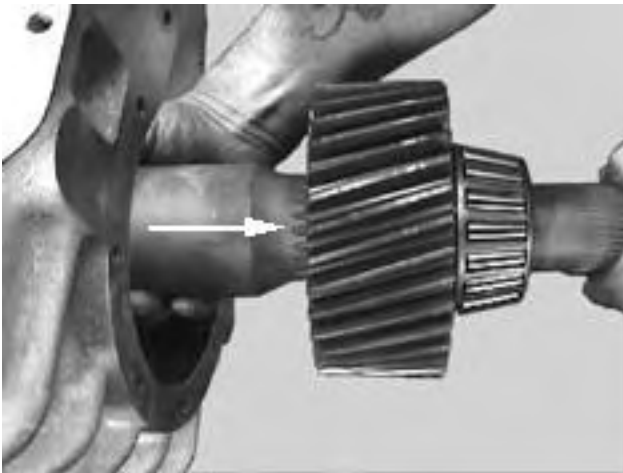

Fig. 25

30. This completes the main disassembly of the transfer case.

## DISSASSEMBLY OF THE SUB-ASSEMBLIES

### INPUT SHAFT

1. After the input shaft has been removed from the housing, the two rear most bearings and the direct-drive gear will have been removed from the shaft.
2. Press the remaining direct-drive gear support bearing off of the shaft as shown. See Fig. 26.

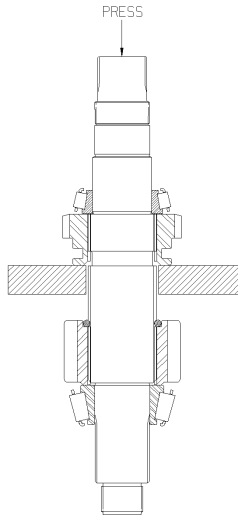

Fig. 26

3. Invert the shaft and remove the under-drive gear and front support bearing as shown. See Fig. 27.

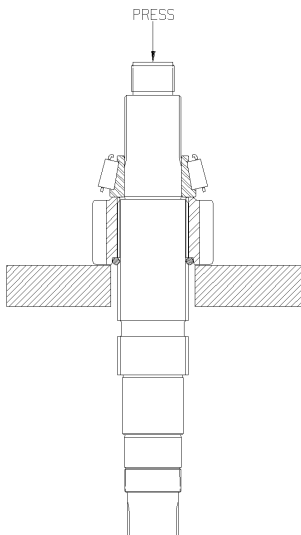

Fig. 27

4. This completes the disassembly of the input shaft.

### INTERMEDIATE SHAFT

1. After the intermediate shaft has been removed from the housing, the rear support bearing and the direct-drive gear will have been removed from the shaft.
2. Heat the bearing locknut slightly to soften locking compound and remove using special tool # 866-0687-002.
3. Press the under-drive gear and all bearings off of the shaft as shown. See Fig. 28.

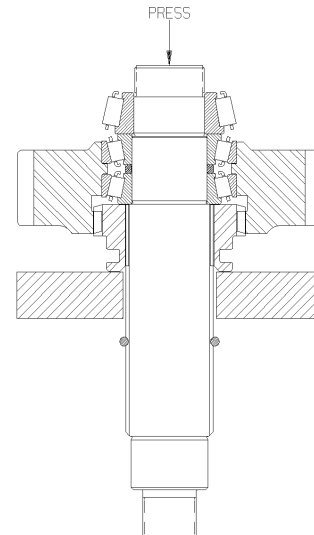

Fig. 28

### REAR OUTPUT SHAFT

1. Heat the bearing locknut slightly to soften locking compound and remove using special tool # 866-0687-006.
2. Remove front declutch gear along with the speedometer tone ring.
3. Remove front support bearing as shown. See Fig. 29.

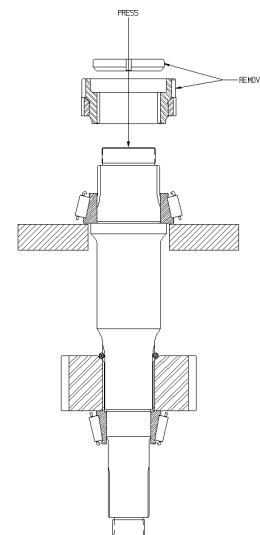

Fig. 29

4. Invert the shaft to remove direct-drive gear and rear support bearing. See Fig. 30.

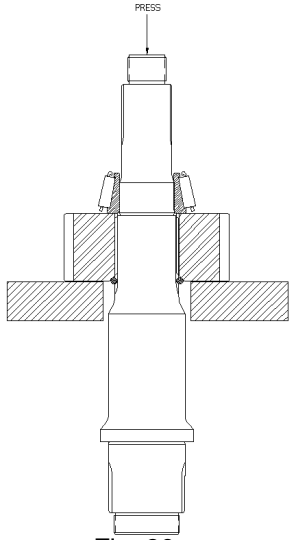

Fig. 30

5. This completes the disassembly of the rear output shaft.

### **FRONT OUTPUT SHAFT**

1. Remove front output carrier, both bearings, and front output shaft gear as shown. See Fig. 31.

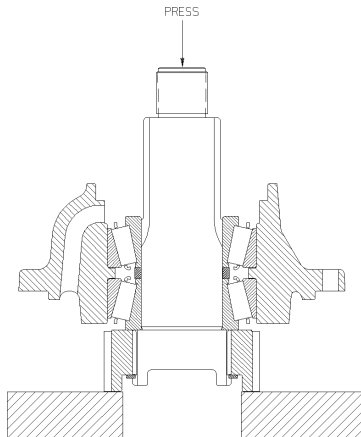

Fig. 31

2. This completes the disassembly of the front output shaft assembly.

## ASSEMBLY

Make sure all parts are clean, dry and lint free. Any traces of storage wax or paper should be removed. Leave bearings and cups in their wrappers, until ready to use. **All threaded holes and fasteners should be cleaned with solvent to ensure that locking compound adheres properly.**

Unless indicated otherwise, part-mating surfaces should be given a light coating of lubricant. Lubriplate is an acceptable grease. A substitute may be utilized consisting of a mixture of chassis grease and 30W engine oil. The mix should be thin enough to apply with a small brush.

**!** **NOTE:** WHEN A PART IS ASSEMBLED WITH A PRESS FIT, IT IS RECOMMENDED THAT THE PART BE HEATED PRIOR TO INSTALLATION IN A SUITABLE OVEN AT A TEMPERATURE NO GREATER THAN 300 F.

### INPUT SHAFT ASSEMBLY

1. Slide retaining ring onto input shaft (using a press and plate) until it is seated in the groove. See Fig 32. (Rear output shaft is shown, method for input shaft similar.)

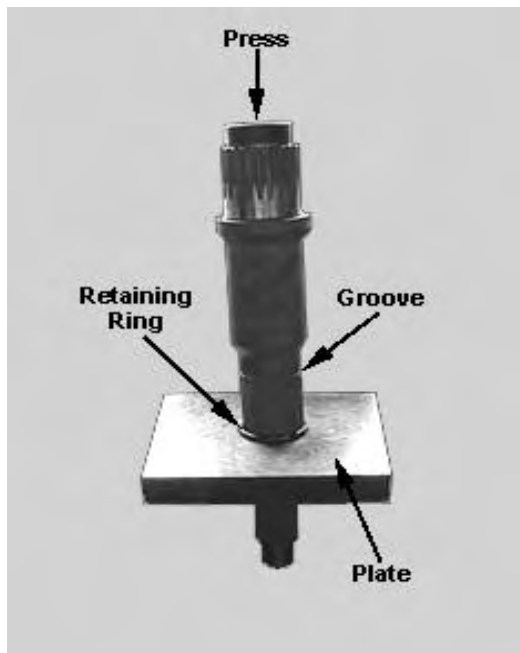

Fig. 32

2. Press the bearing cups into the direct drive gear. Place one in each side.
3. Install the underdrive gear onto the threaded end of the shaft. Check to see that the retaining ring is fully seated in the groove on the underside of the gear. See Fig. 33.

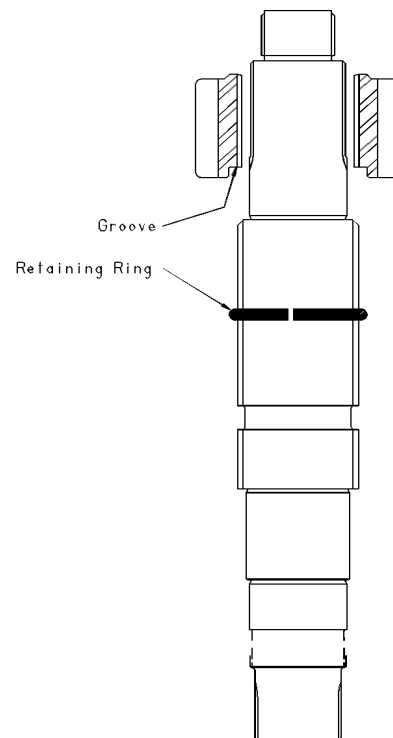

Fig 33

4. Install the heated front bearing onto input shaft, then turn the shaft over and install the clutch gear with the groove down and the teeth up. See Fig. 34.

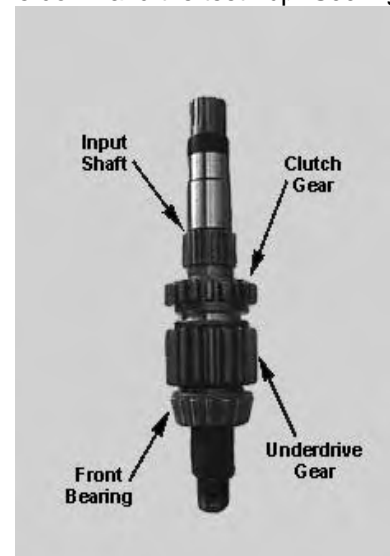

Fig. 34

5. Install the remaining parts onto the shaft in the order shown in Fig. 35 & 36.
  - 5 -- Bearing
  - 6 – Bearing Spacer
  - 7 – Direct-drive Gear
  - 8 – Bearing

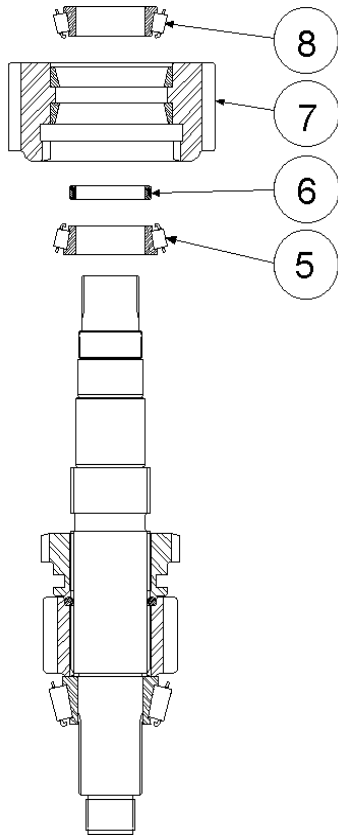

Fig. 35

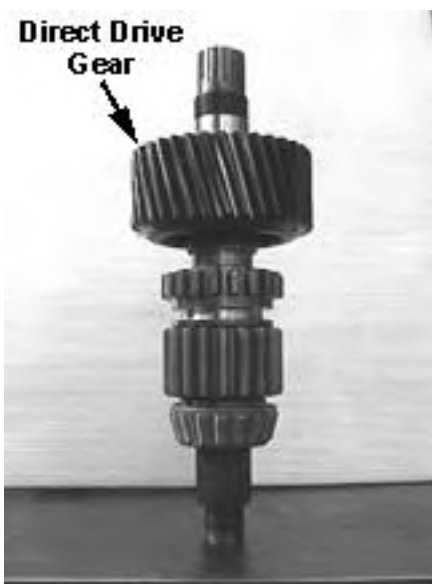

Fig. 36

6. Place the end-float set-up tool onto the shaft and install the rear bearing lock nut using special socket #866-0687-002. Torque to spec. See Fig. 37.

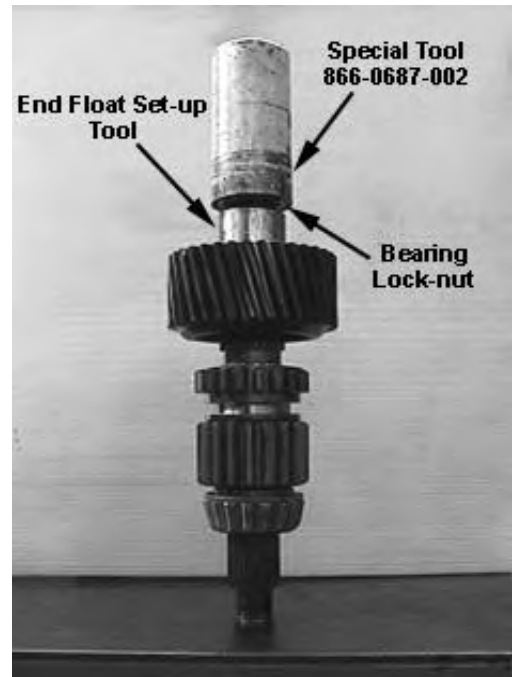

Fig. 37

7. Check gear end-float using a dial indicator as shown below. Clearance should be .000 to .002 inches **loose**. If the end-float is not within the specified limits, (see page 8) another bearing spacer (#6 Fig 35) will need to be selected. See Fig. 38.

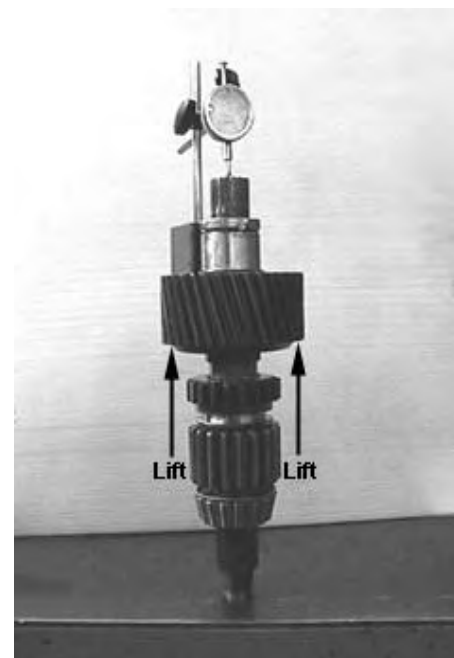

Fig. 38

8. Remove the bearing lock nut and spacer.
9. This completes the assembly of the input shaft.

## INTERMEDIATE SHAFT ASSEMBLY

1. Press the retaining ring onto the shaft.  
See Fig. 32.
2. Press bearing cups into the under drive gear.
3. Place the clutch gear onto the shaft with the groove facing the retaining ring and the small end of the shaft.  
See Fig. 39.

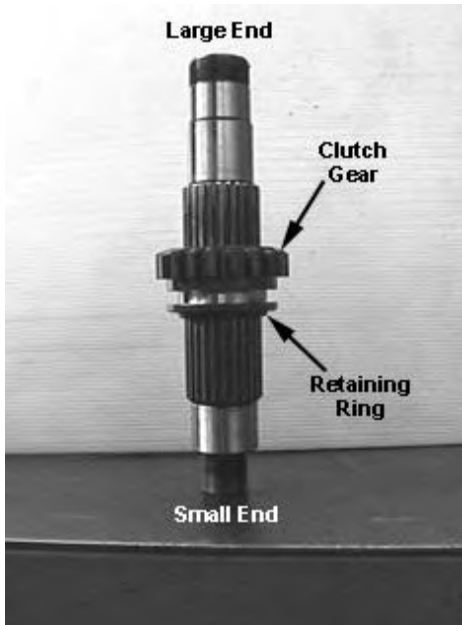

Fig. 39

4. Place a heated bearing (1) onto the large end of the shaft followed by the spacer (2), underdrive gear (3), and rear bearing (4) in the order shown in figure 40.

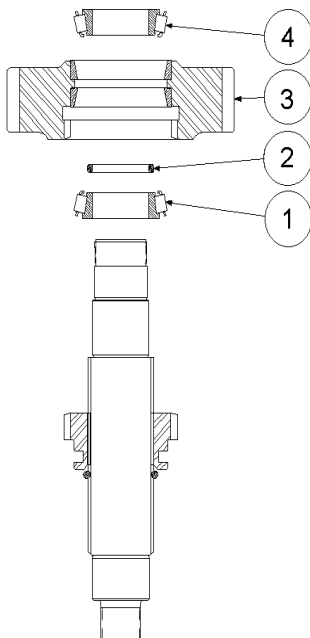
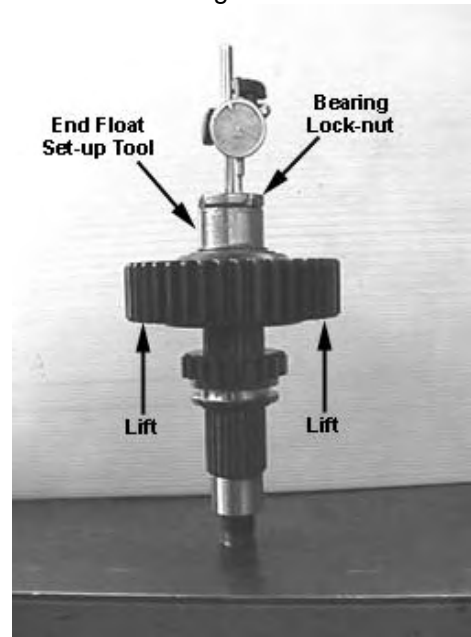

Fig. 40

5. Install the end-float set-up tool and bearing locknut onto the shaft and torque to spec. Measure the end-float using a dial indicator as shown in figure 41. Place the indicator stand base on the gear face.

Fig. 41



6. Gear end-float should be .000 to .002 inches **loose** (see page 8). If the end-float is not within the specifications the gear and rear bearing will need to be removed and a bearing spacer of a different thickness used.
7. Remove the bearing locknut and set-up spacer.
8. Install a heated bearing (1) onto the shaft. Install the bearing locknut (2) using #290 Loctite on the threads and torque to spec. See Fig. 42.

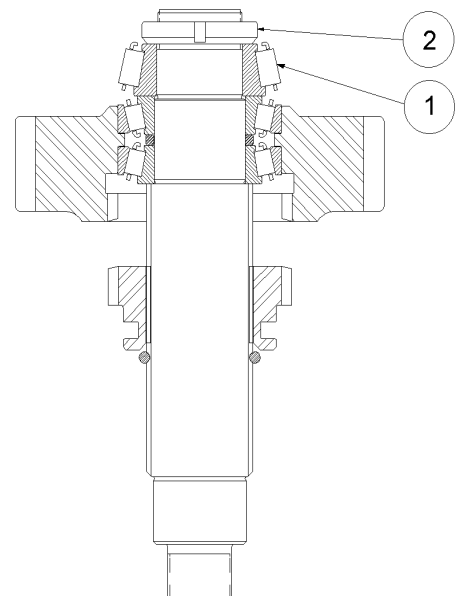

Fig 42

9. This completes the intermediate shaft assembly.

## REAR OUTPUT SHAFT

1. Install the retaining ring into the groove on shaft.  
See Fig. 32.
2. Install a heated bearing onto the shaft so that it is seated against the shoulder.  
See Fig 43.
3. Install the front declutch gear so that the speedometer tone ring is facing the bearing.  
See Fig. 43.

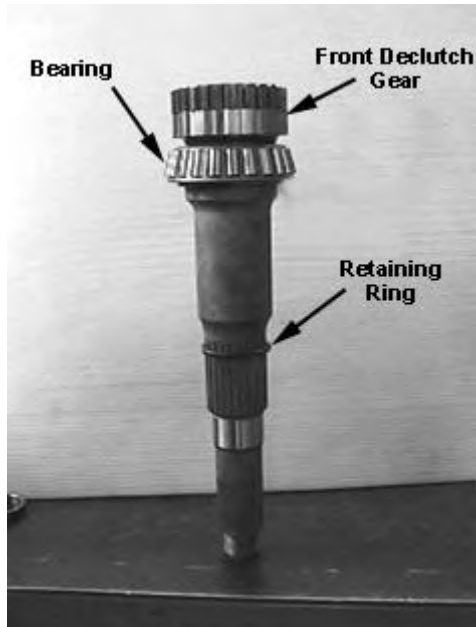

Fig. 43

4. Install the front declutch gear locknut using special socket # 866-0687-004 and Loctite #290 on threads. Torque to spec.
5. This completes the rear output shaft assembly.

## FRONT OUTPUT SHAFT ASSEMBLY

1. Press bearing cups into the front output carrier using the special tool. See Fig. 44.



Fig. 44

2. Install the snap-ring and front output shaft gear onto the front output shaft.  
See Fig. 45.

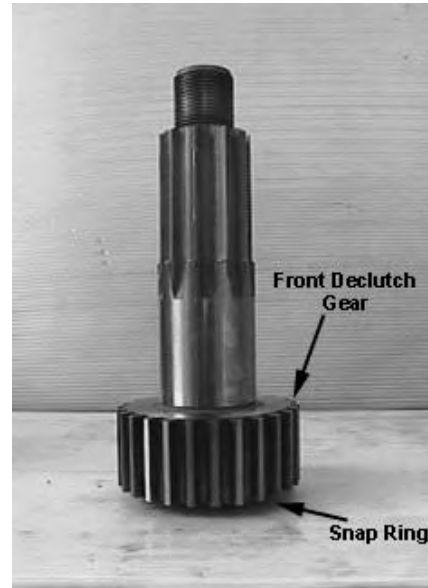

Fig. 45

3. Install a heated bearing (1), bearing spacer (2), front output carrier (3), and heated outer bearing (4) in the order shown in figure 46.

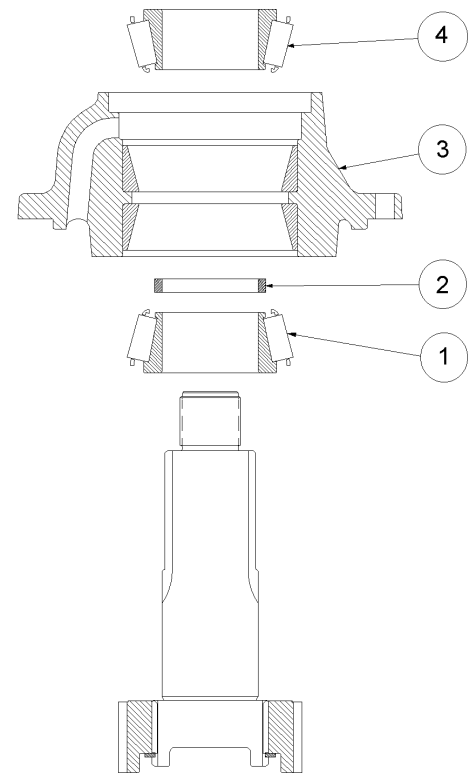

Fig. 46

4. Install the end-float set-up tool or front output yoke and lock nut.

- Torque to spec. using a fixture similar to that shown below.  
See Fig. 47.

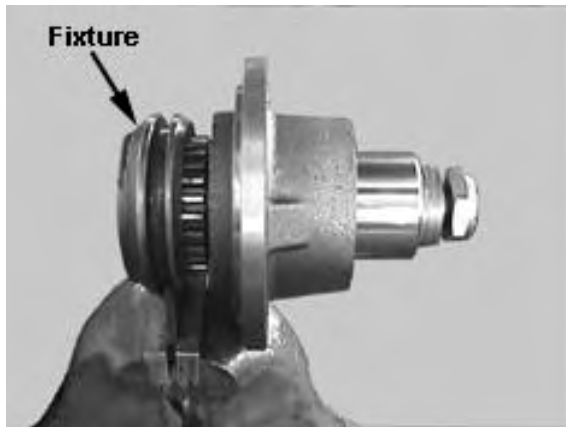

Fig. 47

- Using a dial indicator, measure the shaft end-float. The clearance should be .003 to .008 inches **loose** (see page 8). If the end-float is not within specification a bearing spacer ring of a different thickness will need to be used.  
See Fig. 48.

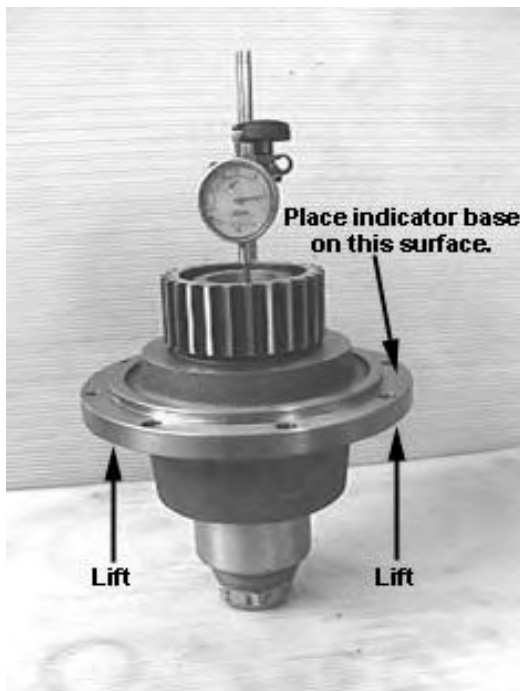

Fig. 48

- Remove the lock nut and end-float set-up tool.
- Install a new front output seal.
- This completes the front output assembly.

## GENERAL ASSEMBLY

1. If the bearing cups were removed from the rear carrier, re-install the shim stack into the intermediate shaft rear bearing bore.  
See Fig. 49.



Fig. 49

2. Install the bearing cups into the rear housing using special tool # 424-0443. See Fig. 50.



Fig. 50

3. Install a new rear-output seal into the rear housing.
4. Install the intermediate shaft front bearing cup into main housing using special tool #866-0780. See Fig. 51.



Fig. 51

5. Place the housing into a suitable assembly stand or on a sturdy workbench.  
See Fig. 52.



Fig. 52

6. Remove the direct-drive gear from the input shaft and place it into the housing such that the shaft may pass through it.  
See Fig. 53.



Fig. 53

7. Install the input shaft (1) into the housing while passing it through the direct-drive gear (2). Re-install the rear bearing (3).  
See Fig. 54.

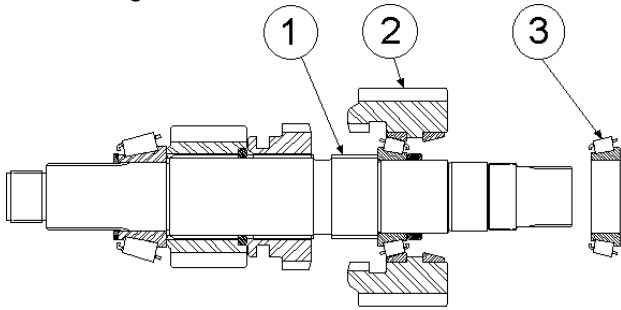

Fig. 54

8. Install the front bearing cup into housing leaving it protruding slightly.  
See Fig. 55.



Fig. 55

9. Install a new seal into input shaft seal carrier using an arbor press or similar as shown.  
See Fig. 56.



Fig. 56

10. Install the input shaft seal carrier to the case using a new gasket. Use Loctite #272 on bolt threads and torque to spec. in a criss-cross pattern.
11. Install the rearmost input shaft support bearing (hot) and bearing locknut, using Loctite #290 on the threads. Torque to spec.
12. Install the rear outer bearing cup into housing followed by the bearing cup spacer.  
See Fig. 57.



Fig. 57

13. Install the gasket shims that were removed during disassembly and install the input shaft rear cap. Use Loctite #272 on bolt threads and torque to spec.  
See Fig. 58.

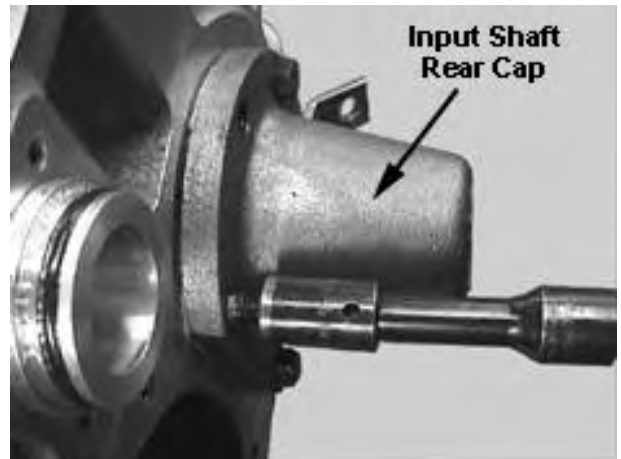

Fig. 58

14. Install the input shaft washer in front of the forward most bearing on the shaft. Install the input shaft yoke and torque the locknut to spec.
15. Temporarily bolt the shift shaft cap on to the front of the housing using one bolt. This will provide a base for a dial indicator.  
See Fig. 59.



Fig. 59

16. Lightly tap the shaft to rear of the case to seat the bearing.  
See Fig. 60.



Fig. 60

17. Measure the input shaft end float using a dial indicator placed on the shift shaft cap. End float should be .003 in **tight** to .003 in. **loose** (page 8) If the end float is not within the specifications the input shaft rear cap will need to be removed and shim gaskets of a different thickness used.  
See Fig. 61.



Fig. 61

18. Install the rear output, front bearing cup into the housing. See Fig. 62.

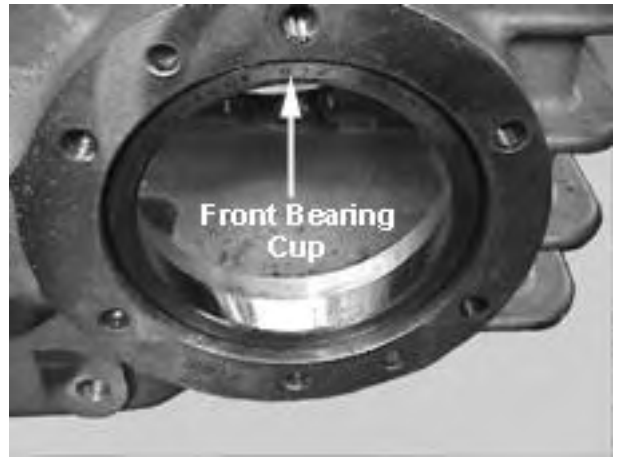

Fig. 62

19. Install all declutch housing gasket shims that were removed during disassembly. Install the declutch housing on to the main housing using Loctite #272. Torque the bolts to spec. in a criss-cross pattern.  
See Fig. 63.



Fig. 63

20. Install rear output shaft into housing from the rear.  
See Fig. 64.



Fig. 64

21. Install intermediate shaft assembly into housing.  
See Fig. 65.

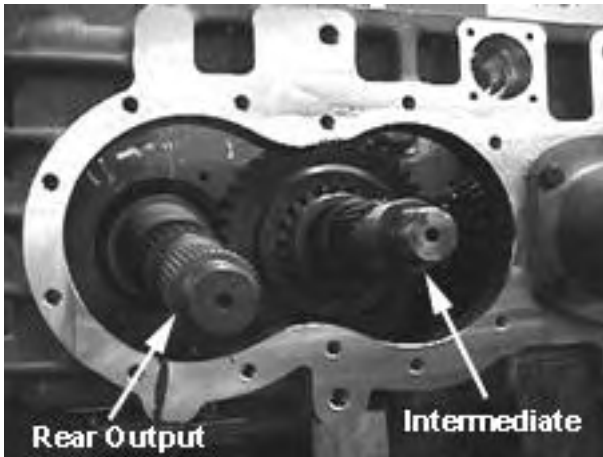

Fig. 65

22. Install a direct drive gear onto the intermediate and rear output shafts until the retaining rings are fully seated into the grooves on both of the direct drive gears.  
See Fig. 66.

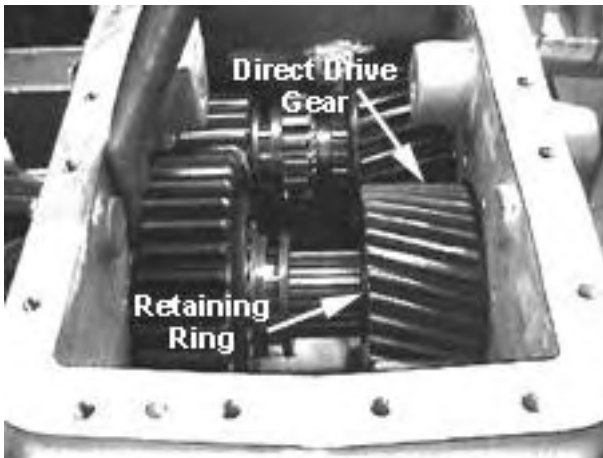

Fig. 66

23. Install heated bearings onto the intermediate and rear output shafts.

24. Install a washer and locknut onto the intermediate shaft using Loctite #290 on the threads. Torque to spec.  
See Fig. 67.

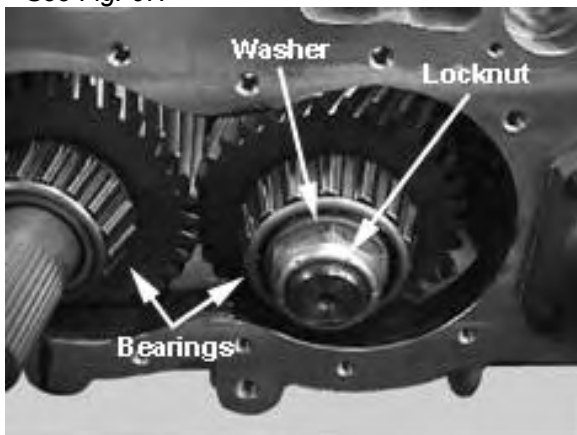

Fig. 67

25. Slide the spacer onto rear output shaft. See Fig. 68.

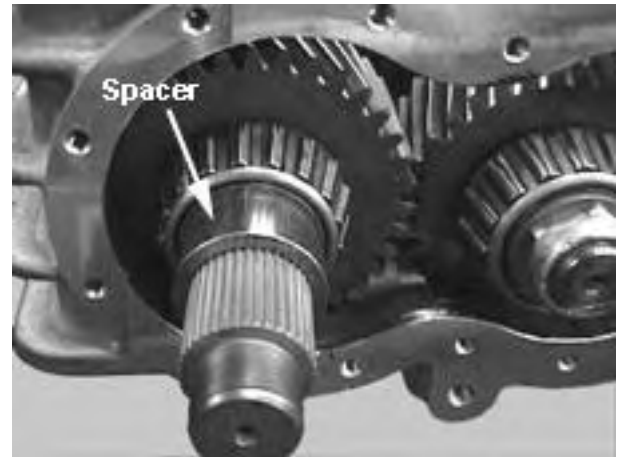

Fig. 68

26. Install a gasket and the rear housing onto the case. Use Loctite #272 on all bolts and torque to spec.  
See Fig. 69.



Fig. 69

27. If not already completed, Drive a new seal into the rear housing using special tool # 866-0782. See Fig. 70



Fig. 70

28. Check the intermediate shaft end float using a dial indicator through the vent hole in the front of the case. Pry the shaft toward the rear of the case to seat the bearing. Zero the indicator and then pry the shaft forward. The endplay should be .003 in. **tight** to .003 in. **loose** (see page 8). If the endplay is not within specification the rear carrier and intermediate shaft rear bearing cup will need to be removed and shims of the proper thickness inserted behind the bearing cup. See Figs. 71 & 72.



Fig. 71.

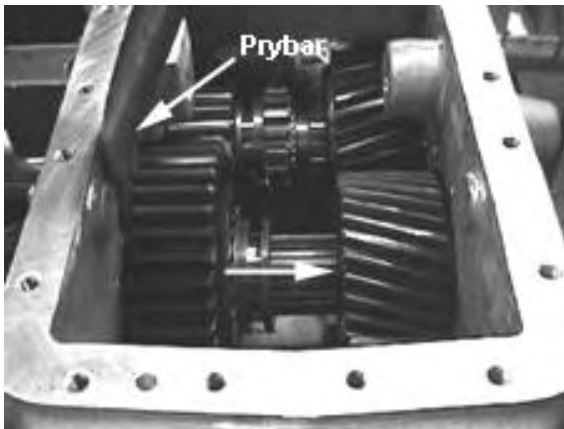

Fig. 72

29. Install the rear output yoke onto the shaft and torque to spec. See Fig. 73.

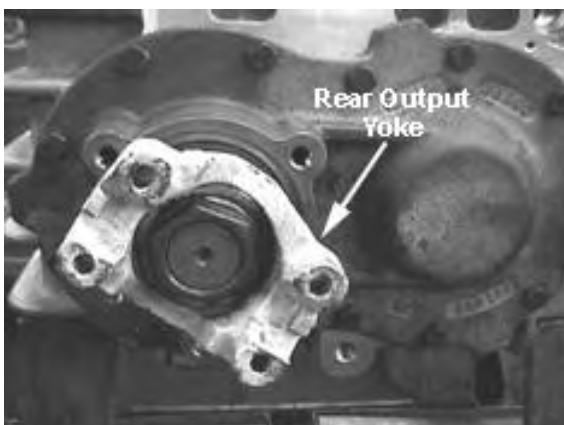

Fig. 73

30. Tap rear output shaft toward the front of the case to seat the bearing against the front declutch housing. See Fig. 74.

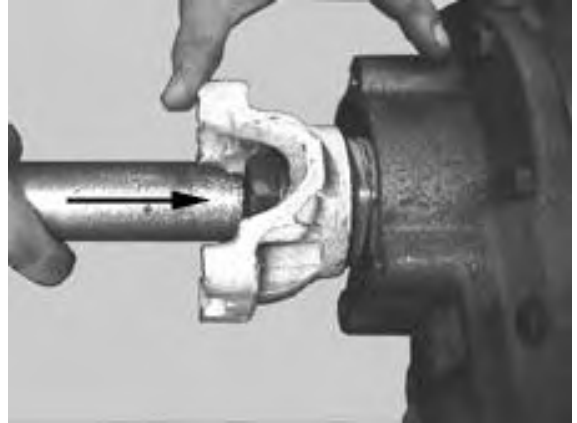

Fig. 74

31. Measure the rear output shaft endplay using a dial indicator. The endplay should be .003 inches **tight** to .003 inches **loose** (see page 8). If the endplay is not within the specification the front declutch housing will need to be removed and shim gaskets of the proper thickness used. See Fig. 75.



Fig. 75

32. Place new o-rings onto all shift cylinder components that were disassembled. Coat all o-rings with Lubriplate or similar.

33. Place the front declutch shift fork and collar into housing. See Fig. 76.

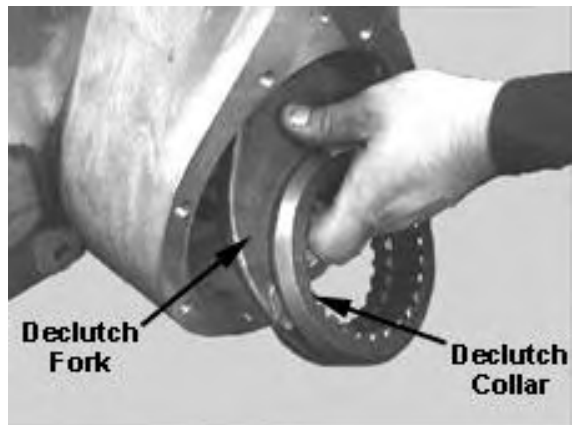

Fig. 76

34. Install the shift shaft into the housing and declutch fork. Align the notches in the shaft with the holes in the fork. Install bolts. Torque to spec. and lock-wire as shown. See Fig. 77.

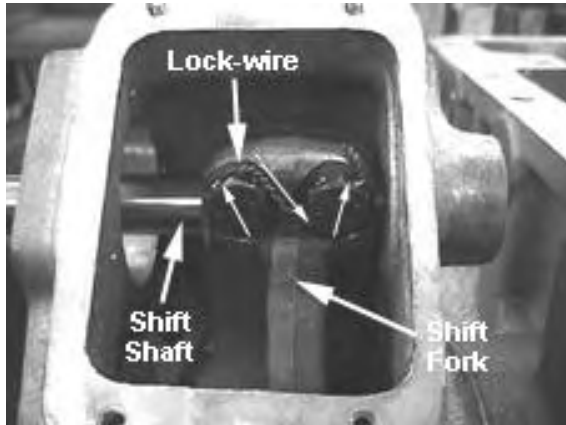

Fig. 77

35. Install the o-ring onto the shoulder of shift shaft.  
36. Install the shift cylinder adapter into the case. See Fig. 78.

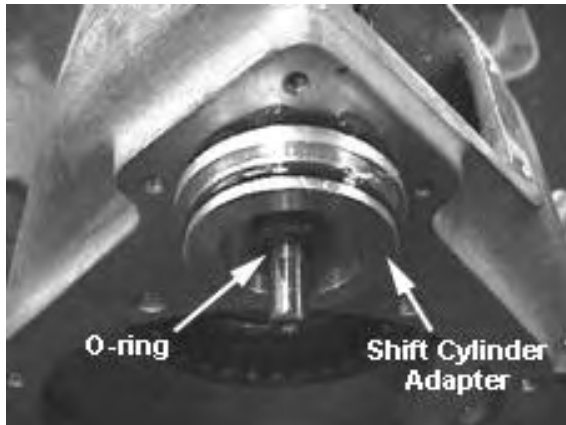

Fig. 78

37. Install the declutch shift spring, nylon stop ring, and shift piston onto shift shaft. Use Loctite #272 on threads and torque piston retaining nut to spec. See Fig. 79.

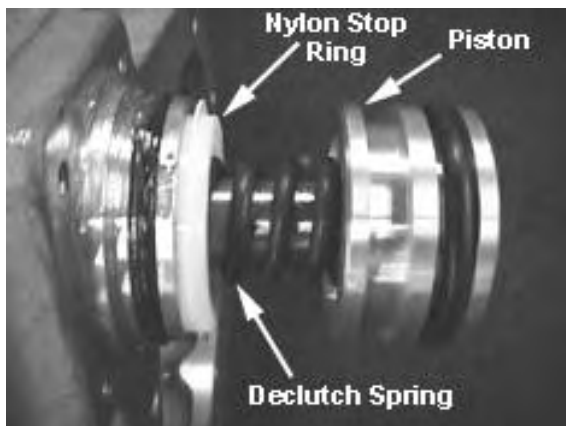

Fig. 79

38. Install an oil-soaked felt wiper into the large groove on the shift piston and install shift cylinder. See Fig. 80.

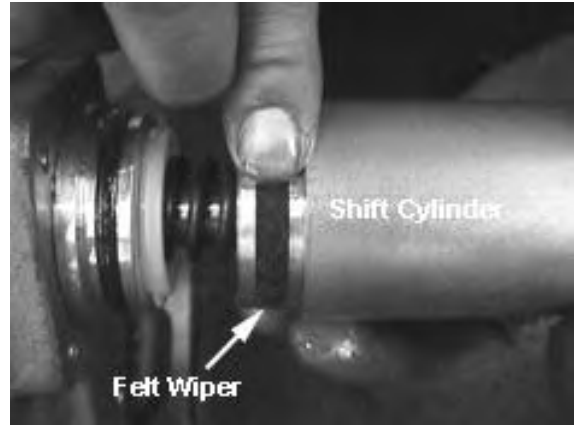

Fig. 80

39. Install the shift cylinder cap using Loctite #242 on the threads. Torque to spec. See Fig. 81.

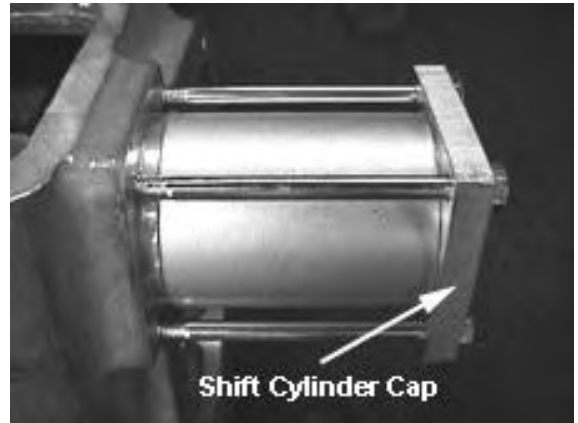

Fig. 81

40. Install the front drive engagement indicator switch pin (3) such that the rounded end of the pin is facing the shift shaft.  
41. Install the indicator switch (1) using one copper washer (2). Note: it may be necessary to use two washers for proper switch operation. See Fig. 82.

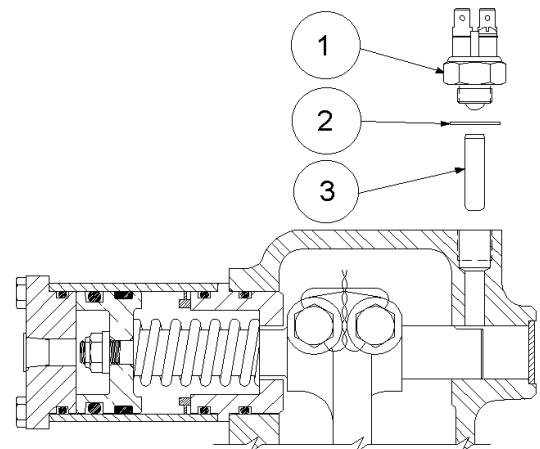

Fig. 82

42. Check for continuity across the leads of the sensor with a continuity tester. The tester should indicate a closed circuit with air pressure applied to the air shift cylinder. See Fig. 83.



Fig. 83

43. Install front output shaft into declutch housing using a new gasket. Align bearing oil drain with the bottom of the case. Apply Loctite #272 to bolt threads and torque to spec. See Fig. 84.

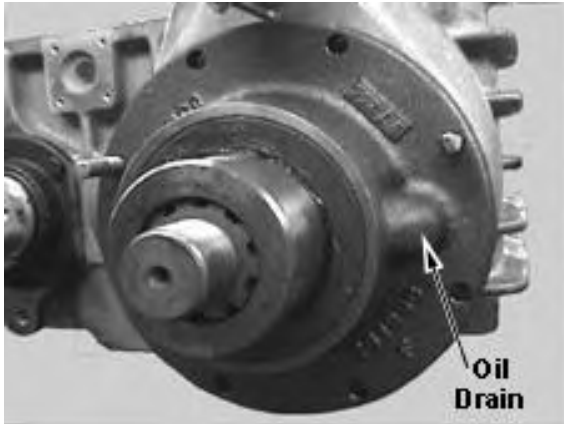

Fig. 84

44. Install front declutch cover plate using Loctite #242 on bolt threads. Torque to spec. See Fig. 85.



Fig. 85

45. Place the range shift forks into the housing with the flat sides facing each other. See Fig. 86.

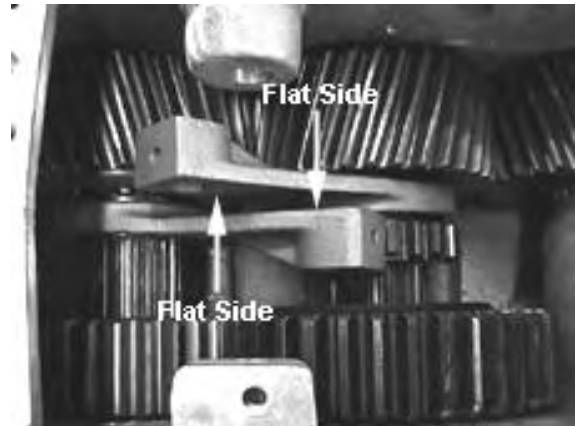

Fig. 86

46. Place a new o-ring on the shoulder of the shaft and install the piston to the shaft using #272 Loctite on the retaining nut threads. Torque to spec. See Fig. 87.

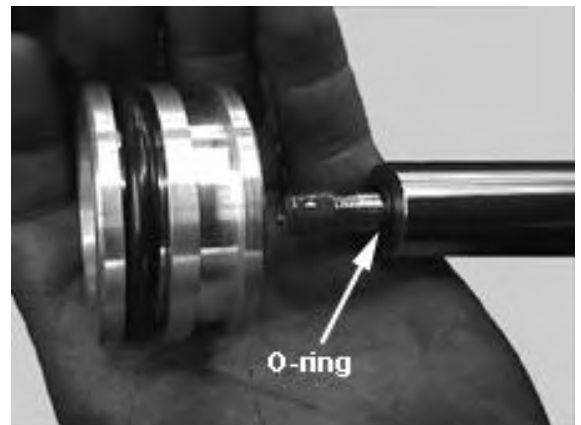

Fig. 87

47. Install the shift cylinder adapter to the housing.  
48. Insert the range shift shaft (containing the shaft, nylon stop ring, and range shift spring) into the housing passing it through the range shift forks. See Fig. 88.

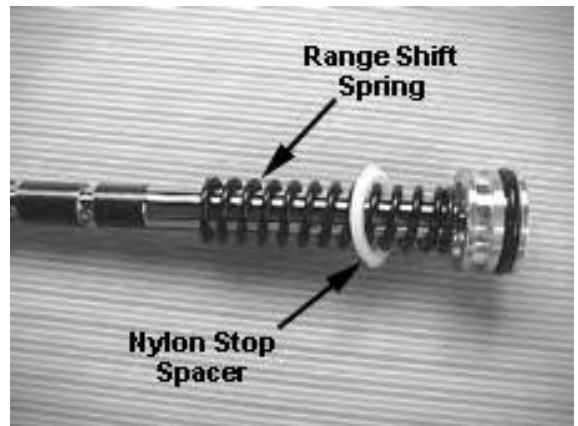

Fig. 88

49. Align the grooves in the shift shaft with the holes in the shift forks. Install bolts with #272 Loctite. Torque to spec. and lock-wire. See Fig. 89.

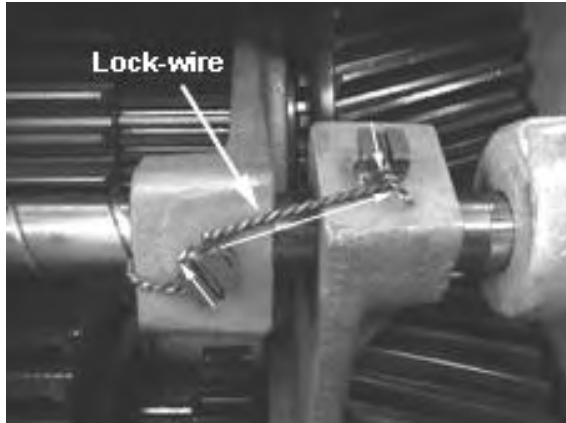

Fig. 89

50. Install an oil soaked felt wiper in the large groove on range shift piston and slide the cylinder onto the piston. See Fig. 90.



Fig. 90

51. Install the shift cylinder cap onto cylinder using Loctite #242 on the bolt threads. Torque to spec. See Fig. 91.

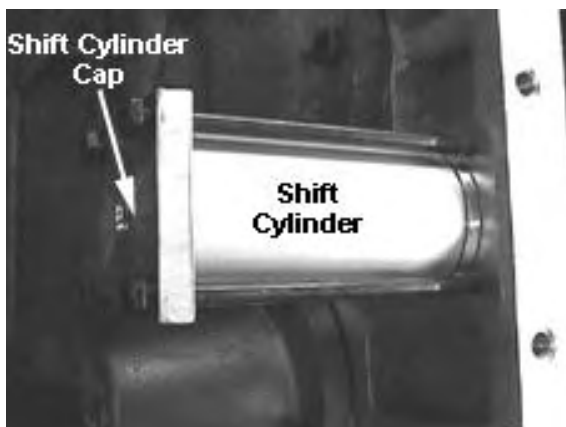

Fig. 91

52. Install the shift shaft cover plate using Loctite #242 on the bolt threads. See Fig. 92.



Fig. 92

53. Install all drain and fill plugs, and/or speed and temperature sensors.
54. Install the housing cover plate using split lock-washers and Loctite #272 on the threads. Torque to spec. See Fig. 93.

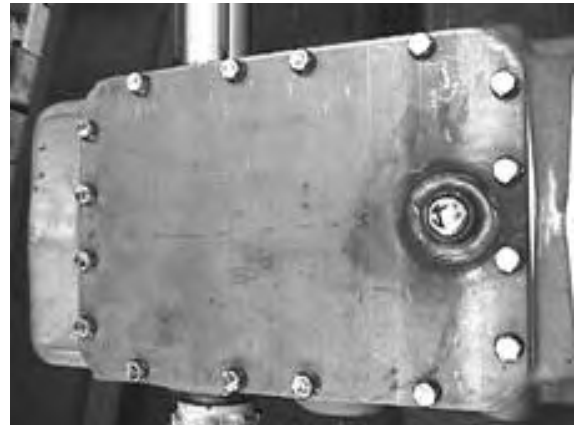
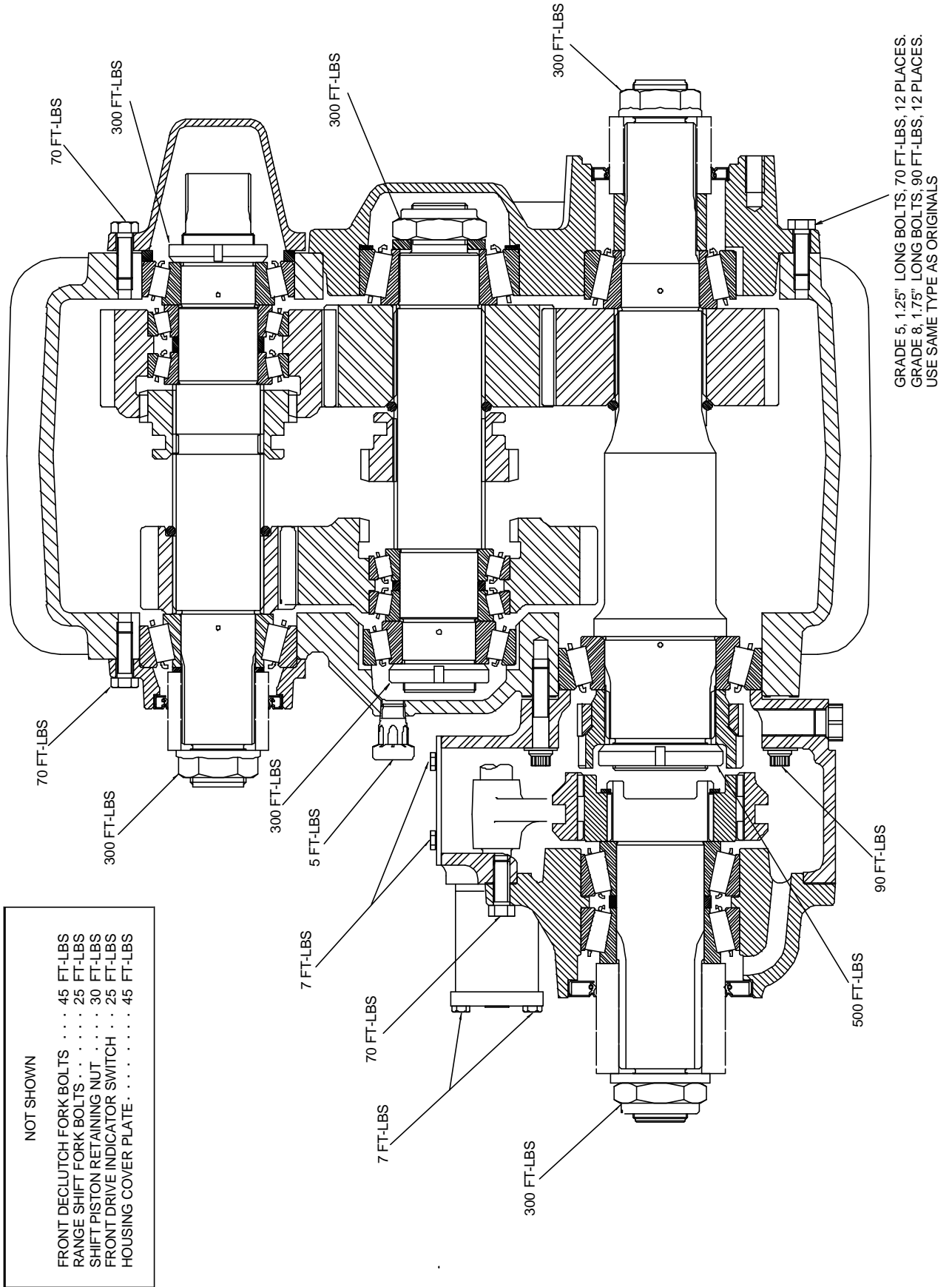

Fig. 93

55. This completes the transfer case main assembly.

# TORQUE SPECIFICATIONS



## **TOOLS**

### **Details of tooling to facilitate the servicing of the Fabco TC-237 Transfer Case.**

Service tools may be manufactured to these drawings or Fabco Automotive may be contacted for price and availability.

The manufacture of these tools should be carried out by professional machinists and certified welders, following typical and good workmanship procedures and safe practices.

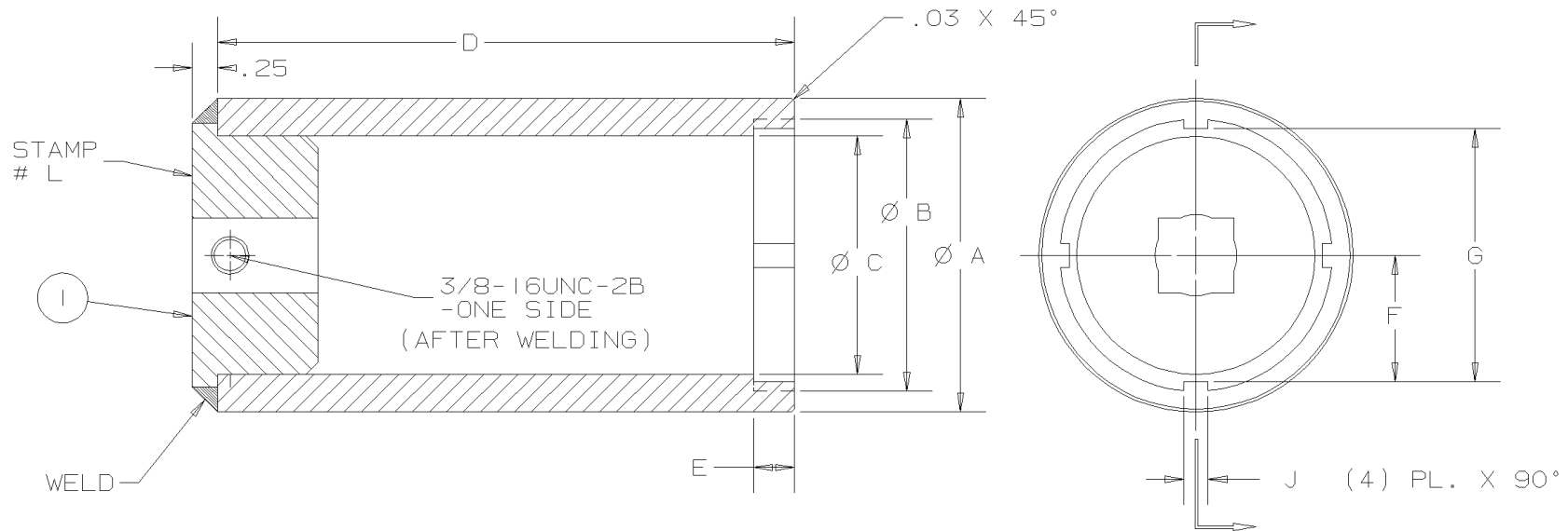
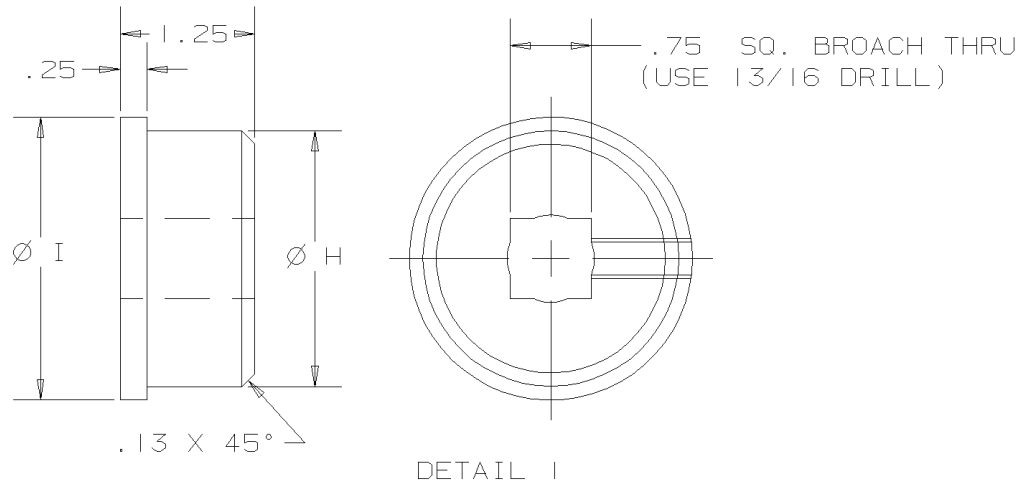

HARDEN WELDMENT TO Rc 40-45  
MATERIAL: 4140 STEEL

PART NO.	ØA	ØB	ØC	D	E	F	G	H	I	J	L	BEARING LOCKNUT		REPLACES TOOL NO.
												SIZE	PART NO.	
866-0687-002	3.13	2.708 2.718	2.364 2.384	5.75	.410	1.265 1.260	2.530 2.520	2.360	2.63	.240 .242	866-0687-002	N10	688-0739	8661600 002
866-0687-004	3.615	3.395 3.405	2.740 2.760	5.75	.535	1.578 1.573	3.156 3.146	2.740	3.25	.240 .242	866-0687-004	N13	688-0645, 688-0746	8661600 003 TRANSFER CASES

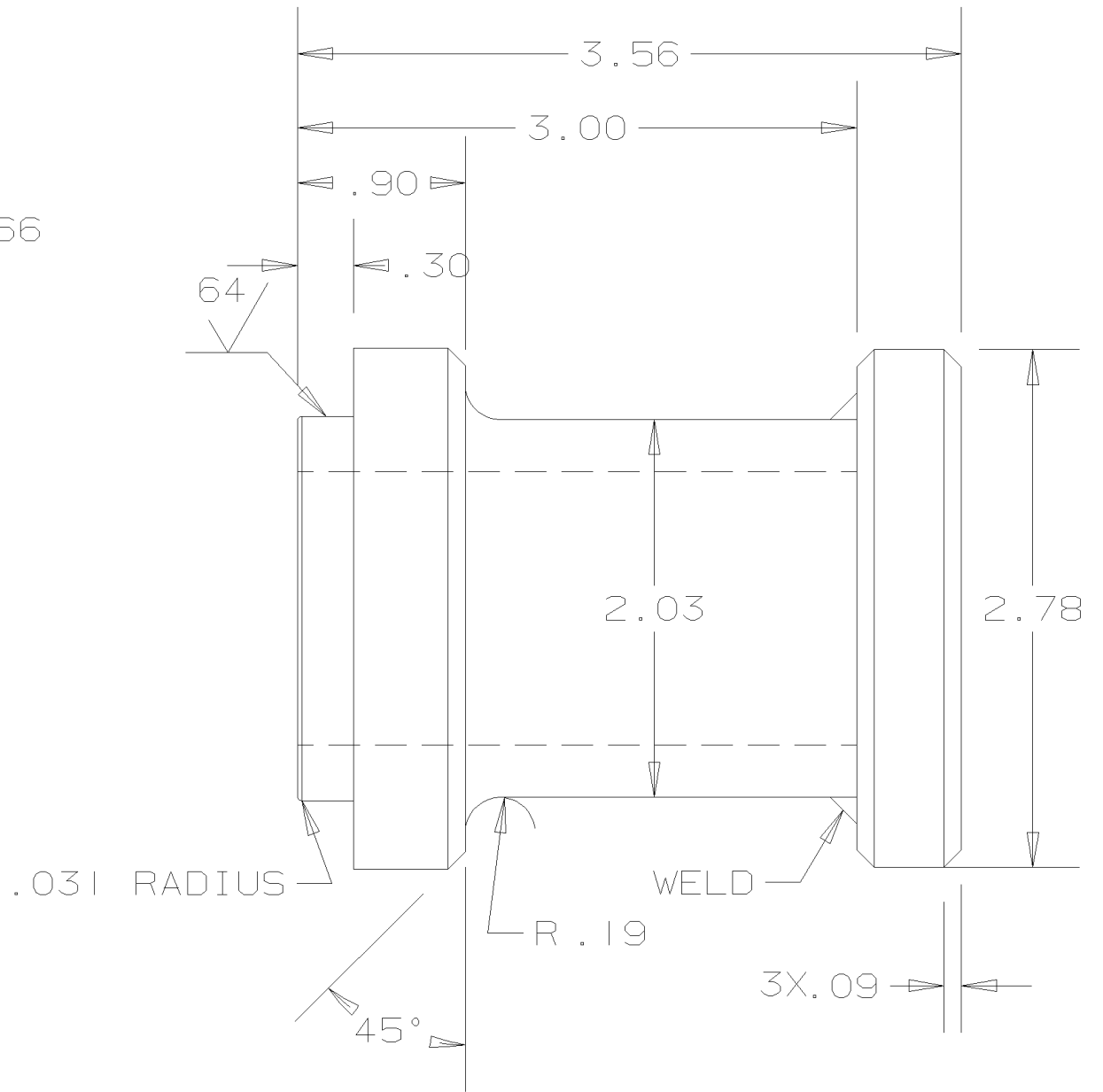
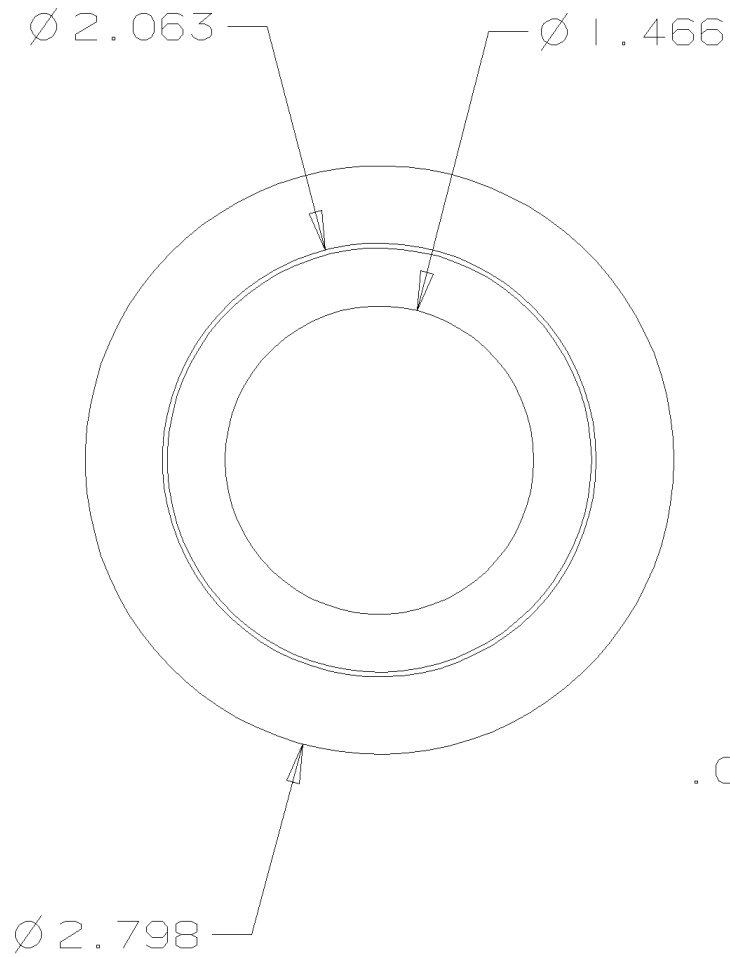

SEAL DRIVER, REAR OUTPUT  
 866-0782 MATERIAL: MILD STEEL

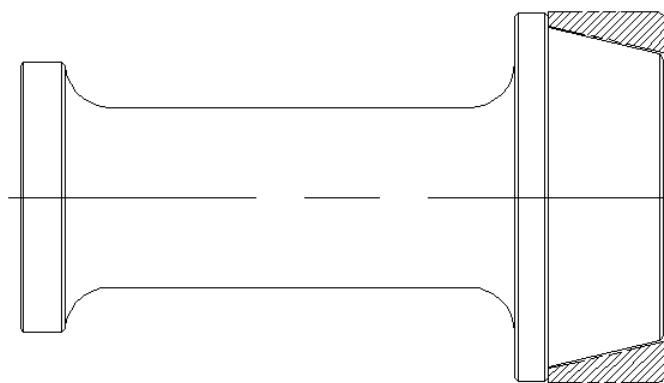
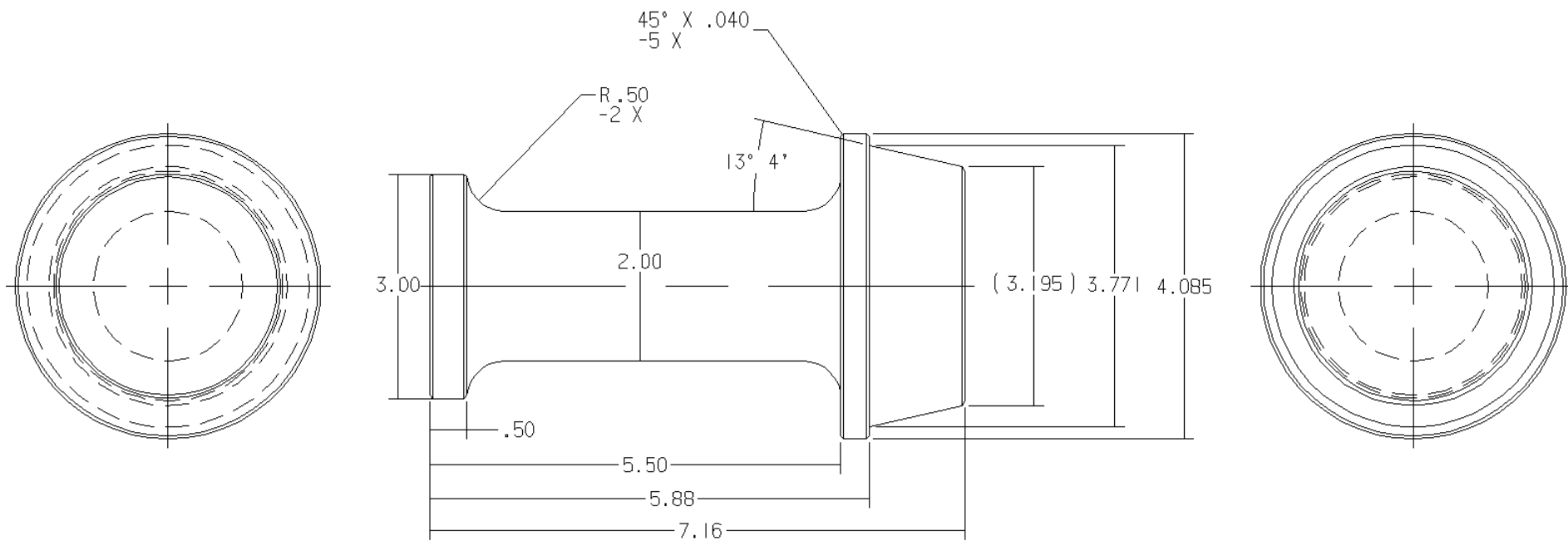

BEARING CUP DRIVER 424-0443  
MILD STEEL

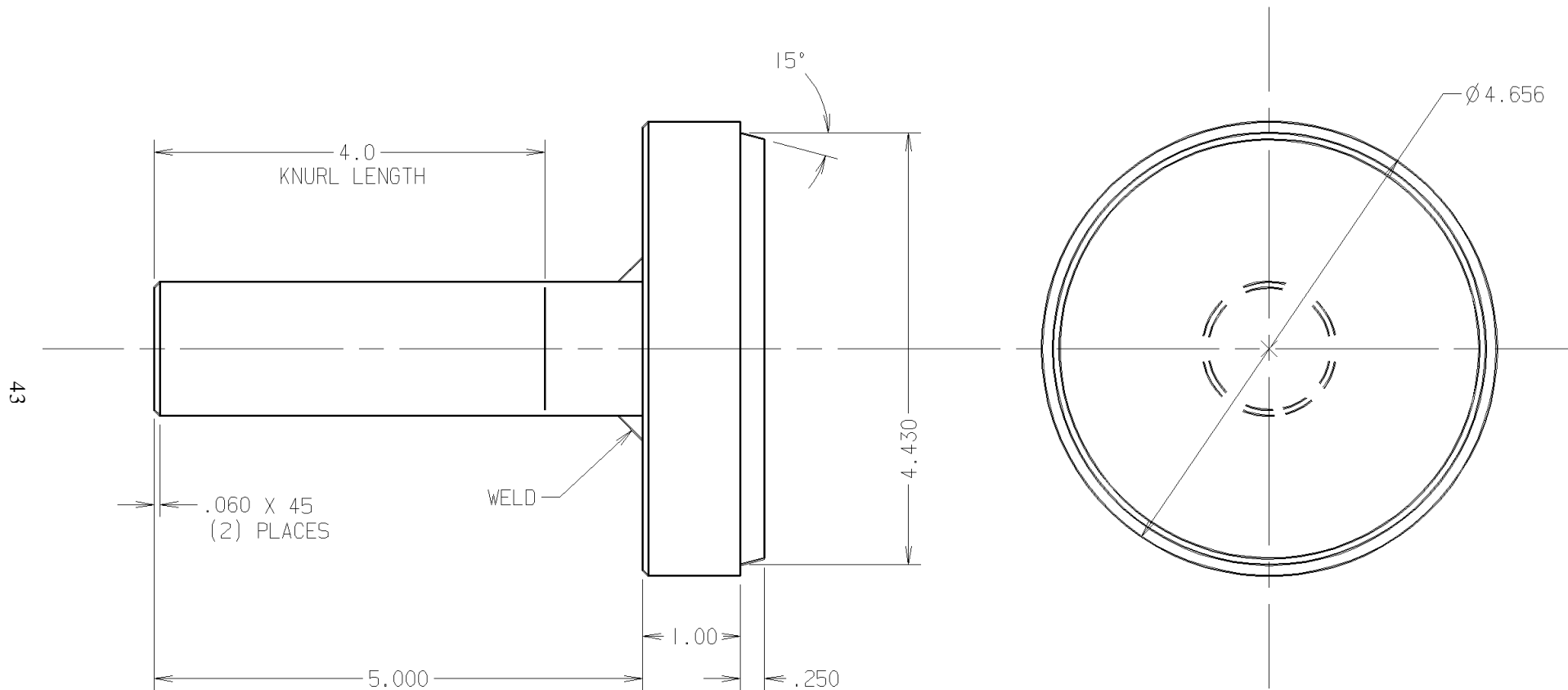

FRONT OUTPUT BEARING CUP DRIVER  
MILD STEEL

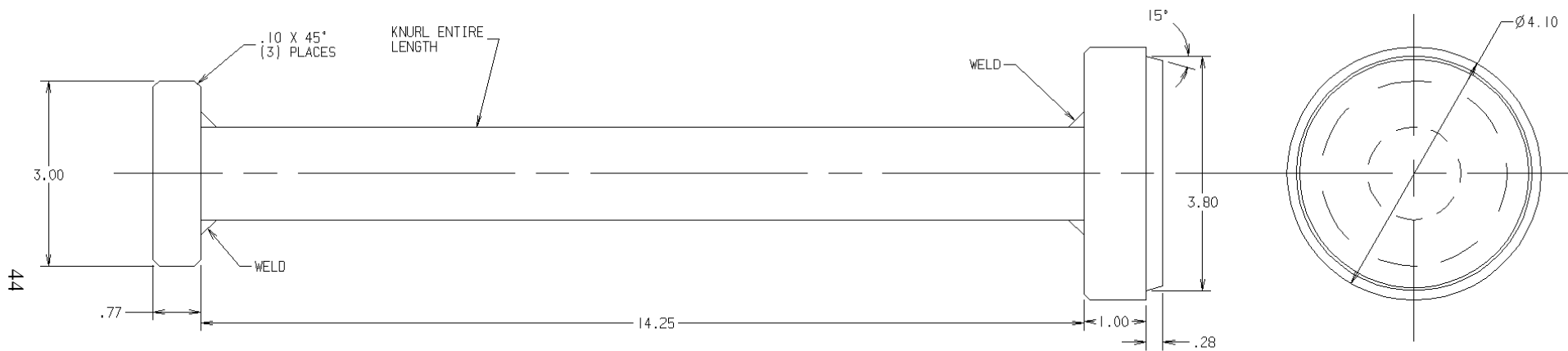

BEARING CUP DRIVER 866-0780  
 MILD STEEL

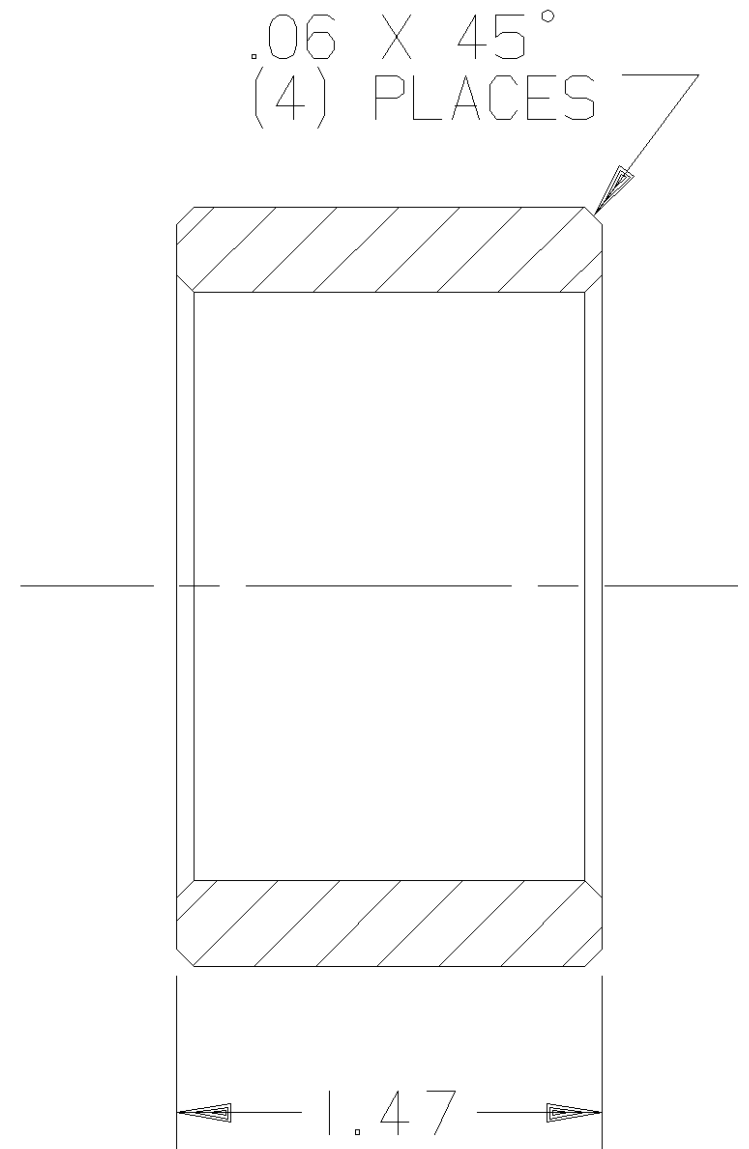
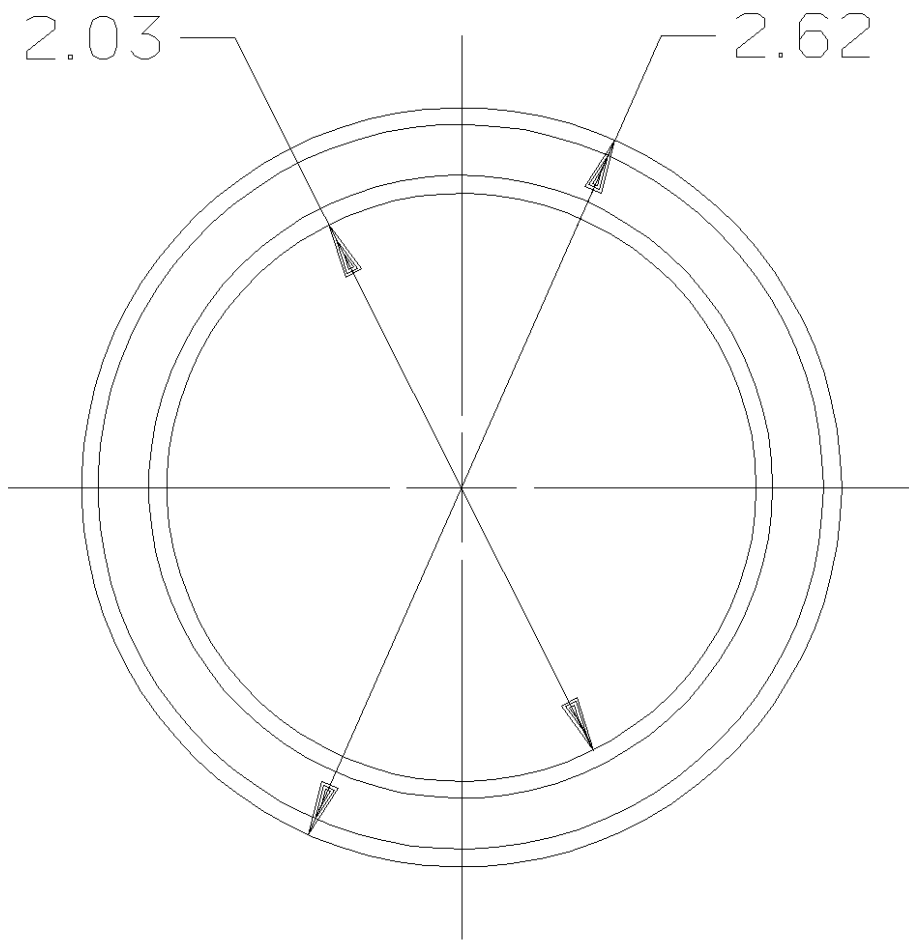

END-FLOAT SETUP TOOL  
MILD STEEL