

# THE INDUSTRY'S TRUSTED LEADER IN NEW & REMAN TRANSFER CASES

CONTACT THE TRANSFER  
CASE SPECIALISTS TODAY  
FOR A QUOTE ON YOUR  
NEXT TRANSFER  
CASE ASSEMBLY  
OR EXPLORE OUR INVENTORY  
OF PARTS

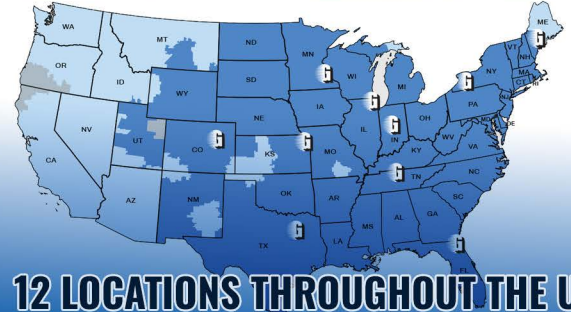

12 LOCATIONS THROUGHOUT THE U.S.

With over 50 years of experience, we are one of the nation's largest suppliers of both new and remanufactured transfer cases.



800-621-3914  
info@generaltruckparts.com



General Truck Parts & Equipment  
4040 W. 40th Street  
Chicago, IL 60632  
generaltruckparts.com/shop



**FABCO TC-270  
TRANSFER CASE PARTS  
MANUAL**



**TC-270 UPPER SHAFT ASSEMBLY**  
**Models without PTO Provisions**

<u>ITEM</u>	<u>PART NO.</u>	<u>DESCRIPTION</u>	<u>QTY.</u>	<u>FOOT NOTE</u>
1	688 738	Nut, 1 3/4-12, Lock	1	
2	732 355	Seal	1	
3	265 238	Bolt, 7/16-14 x 1 1/4 Hex Head	16	
4	927 347	Washer, 7/16 Flat	16	
5	273 687	Bracket, Lifting	2	
6A	237 542 001	Carrier, Front <u>with</u> Lubrication Port	1	
6B	237 542 003	Carrier, Front <u>without</u> Lubrication Port	1	
7	427 523	Gasket	1	
8	233 492	Bearing Cup	1	
9	233 493	Bearing Cone	1	
10	927 797	Washer, Input Shaft Spacer	1	
11	432 628	Gear, Input Shaft	1	
12	776 229	Shaft, Input <u>without</u> PTO Provision	1	
13	966 326	Key	1	
14	233 489	Bearing Cone	1	
15	233 375	Bearing Cup	1	
16	744 278	Shim, .030 Thick, Coral	A/R	1
	744 279	Shim, .015 Thick, Pink	A/R	1
	744 282	Shim, .005 Thick, Blue	A/R	1
	744 283	Shim, .002 Thick, Red	A/R	1
17A	235 568 001	Cap, Top Rear without Lubrication Port	1	
17B	235 568 002	Cap, Top Rear with Lubrication Port	1	

Footnotes:

1. See section 6.2 of service manual for adjustment procedures.

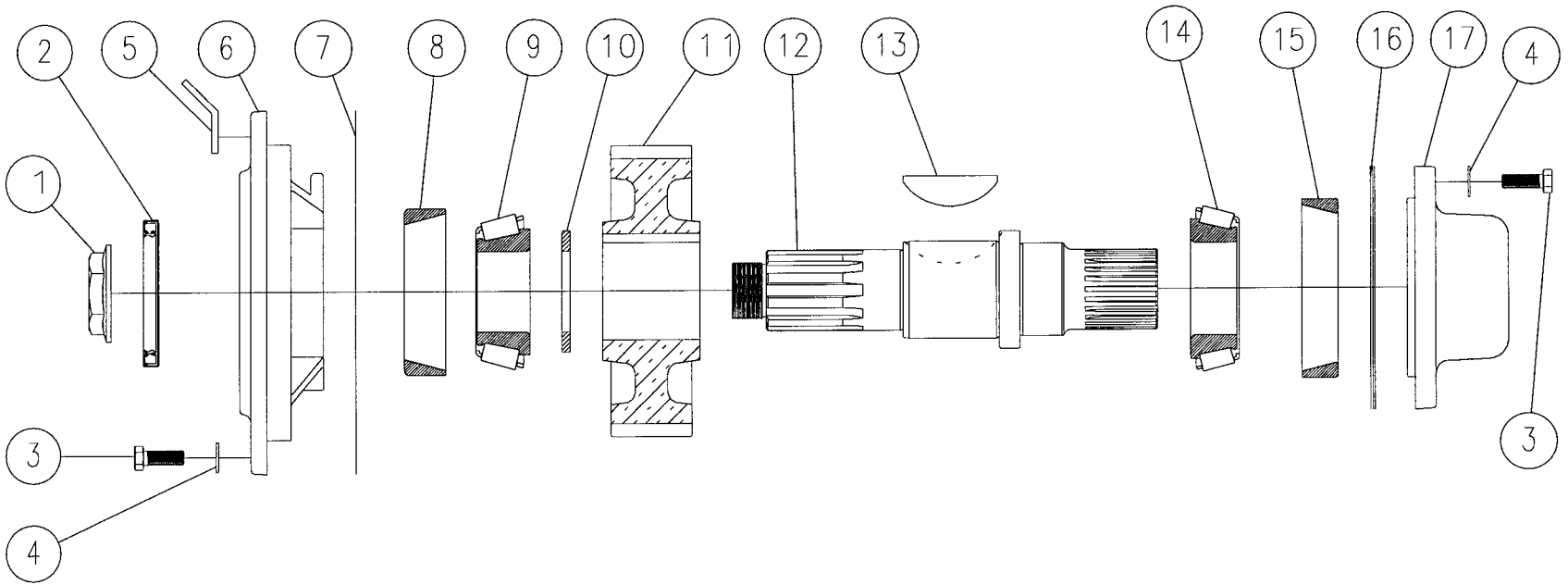

TC-270 UPPER SHAFT ASSEMBLY WITH PTO PROVISIONS

**TC-270 UPPER SHAFT ASSEMBLY**  
**Models with PTO Provisions**

<u>ITEM</u>	<u>PART NO.</u>	<u>DESCRIPTION</u>	<u>QTY.</u>	<u>FOOT NOTE</u>
1	688 738	Nut, 1 3/4-12, Lock	1	
2	732 355	Seal	1	
3	265 238	Bolt, 7/16-14 x 1 1/4 Hex Head	16	
4	927 347	Washer, 7/16 Flat	16	
5	273 687	Bracket, Lifting	2	
6	237 542 003	Carrier, Front <u>with</u> Lubrication Port	1	
7	427 523	Gasket	1	
8	233 492	Bearing Cup	1	
9	233 493	Bearing Cone	1	
10	927 797	Washer, Input Shaft Spacer	1	
11	432 628	Gear, Input Shaft	1	
12	776 257	Shaft, Input <u>with</u> PTO Provision	1	
13	966 326	Key	1	
14	233 489	Bearing Cone	1	
15	233 375	Bearing Cup	1	
16	744 278	Shim, .030 Thick, Coral	A/R	1
	744 279	Shim, .015 Thick, Pink	A/R	1
	744 282	Shim, .005 Thick, Blue	A/R	1
	744 283	Shim, .002 Thick, Red	A/R	1
17	235 655	Cap, Top Rear (PTO Provisions model)	1	

Footnotes:

1. See section 6.2 of service manual for adjustment procedures.

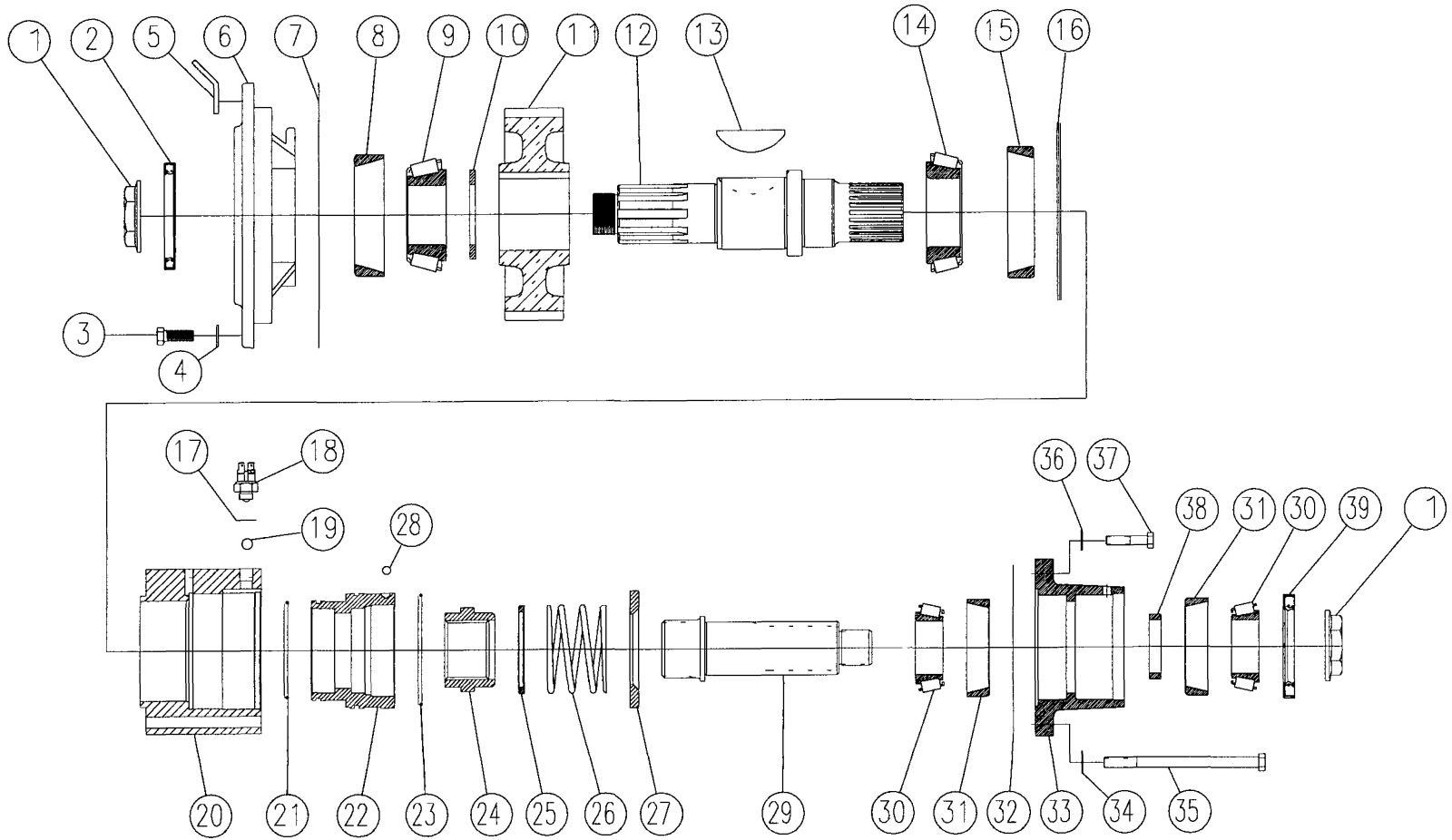

TC-270 UPPER SHAFT ASSEMBLY WITH PTO

**TC-270 UPPER SHAFT ASSEMBLY**  
**Models with PTO**

<u>ITEM</u>	<u>PART NO.</u>	<u>DESCRIPTION</u>	<u>QTY.</u>	<u>FOOT NOTE</u>	<u>ITEM</u>	<u>PART NO.</u>	<u>DESCRIPTION</u>	<u>QTY.</u>	<u>FOOT NOTE</u>
1	688 738	Nut, 1 3/4-12, Lock	2		21	675 241 V14	O-Ring, 3 7/8 ID x 1/8		
2	732 355	Seal	1		22	753 247	Piston, Annular	1	
3	265 238	Bolt, 7/16-14 X 1 1/4 Hex Head	8		23	675 246 V14	O-Ring, 4 1/2 ID x 1/8	1	
4	927 347	Washer, 7/16 Flat	8		24	432 664	Gear, Declutch	1	
5	273 687	Bracket, Lifting	2		25	756 254	Ring	1	
6	237 542 003	Carrier, Front with Lubrication Port	1		26	777 542	Spring	1	
7	427 523	Gasket	1		27	756 253	Ring	1	
8	233 492	Bearing Cup	1		28	225 222	Ball, 3/8 Diameter, Steel	1	
9	233 493	Bearing Cone	1		29	776 258	Shaft	1	
10	927 797	Washer, Input Shaft Spacer	1		30	233 536	Bearing Cone	2	
11	432 628	Gear, Input Shaft	1		31	233 352	Bearing Cup	2	
12	776 257	Shaft, Input <u>with</u> PTO Provision	1		32	728 232	Loctite, 515	3 oz.	
13	966 326	Woodruff Key	1		33	237 577	Carrier	1	
14	233 489	Bearing Cone	1		34	927 347	Washer, 7/16 SAE Flat	6	
15	233 375	Bearing Cup	1		35	283 237	Capscrew, 7/16-14 x 6, Grade 5	6	
16	744 278	Shim, .030 Thick, Coral	A/R	1	36	927 337	Washer, 3/8 SAE Flat	2	
	744 279	Shim, .015 Thick, Pink	A/R	1	37	265 483	Capscrew, 3/8-16 x 1 3/4 Hex Head, Grade 5	2	
	744 282	Shim, .005 Thick, Blue	A/R	1	38	756 249 001	Ring, Bearing Spacer, .396 Thick		2
	744 283	Shim, .002 Thick, Red	A/R	1		756 249 002	Ring, Bearing Spacer, .402 Thick		2
17	927 427	Washer, Switch Spacer	1			756 249 003	Ring, Bearing Spacer, .408 Thick		2
18	798 245	Switch, Shift Indicator	1			756 249 004	Ring, Bearing Spacer, .414 Thick		2
19	225 286	Ball, 1/2 Diameter, Steel	1			756 249 005	Ring, Bearing Spacer, .420 Thick		2
20	478 243	Housing, Declutch	1			756 249 006	Ring, Bearing Spacer, .426 Thick		2
						756 249 007	Ring, Bearing Spacer, .432 Thick		2
					39	732 389	Seal	1	

Footnotes:

1. Select shims, item #16, to obtain .003 to .008 end float on the input shaft.
2. Select one spacer ring to give .001T to .005L end play with output yoke or sealing ring installed.

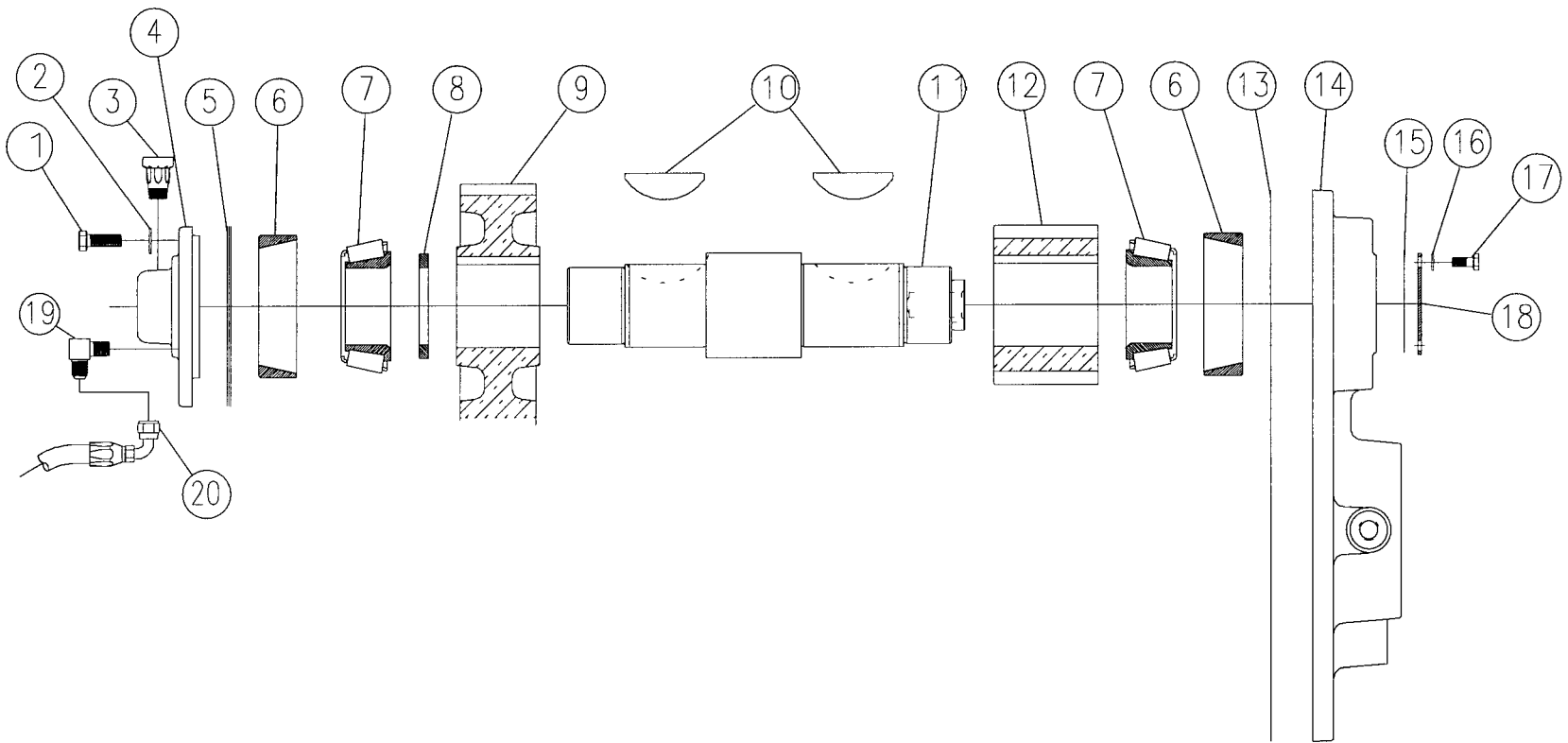

TC-270 INTERMEDIATE SHAFT ASSEMBLY WITHOUT LUBRICATION

**TC-270 INTERMEDIATE SHAFT ASSEMBLY**  
**Models without Lubrication**

<u>ITEM</u>	<u>PART NO.</u>	<u>DESCRIPTION</u>	<u>QTY.</u>	<u>FOOT NOTE</u>
1	265 238	Bolt, 7/16-14 x 1 1/4 Hex Head	6	
2	927 347	Washer, 7/16 Flat	6	
3	836 223	Breather	1	
4	235 572 003	Cap, Intermediate Front	1	
5	744 356 001	Shim, .002 Thick, Red	A/R	1
	744 356 002	Shim, .005 Thick, Blue	A/R	1
	744 356 003	Shim, .015 Thick, Pink	A/R	1
	744 356 004	Shim, .030 Thick, Coral	A/R	1
6	233 586	Bearing Cup	2	
7	233 587	Bearing Cone	2	
8	927 842	Washer, Spacer	1	
9	432 629	Gear, Intermediate Direct	1	
10	966 326	Key	2	
11	776 326	Shaft, Intermediate	1	
12	432 695	Gear, Intermediate Underdrive	1	
13	427 542	Gasket	1	
14	237 635	Carrier, Rear	1	
15	427 468	Gasket	1	
16	927 299	Washer, 5/16, Lock	6	
17	283 245	Bolt, Hex Head, 5/16-18 x 3	6	
18	235 633	Cap, Lubrication Pump Blanking	1	
19	357 898	Elbow, 90°	1	
20	469 822 050	Hose Assembly	1	

Footnotes:

1. See section 6.3 of service manual for adjustment procedure.

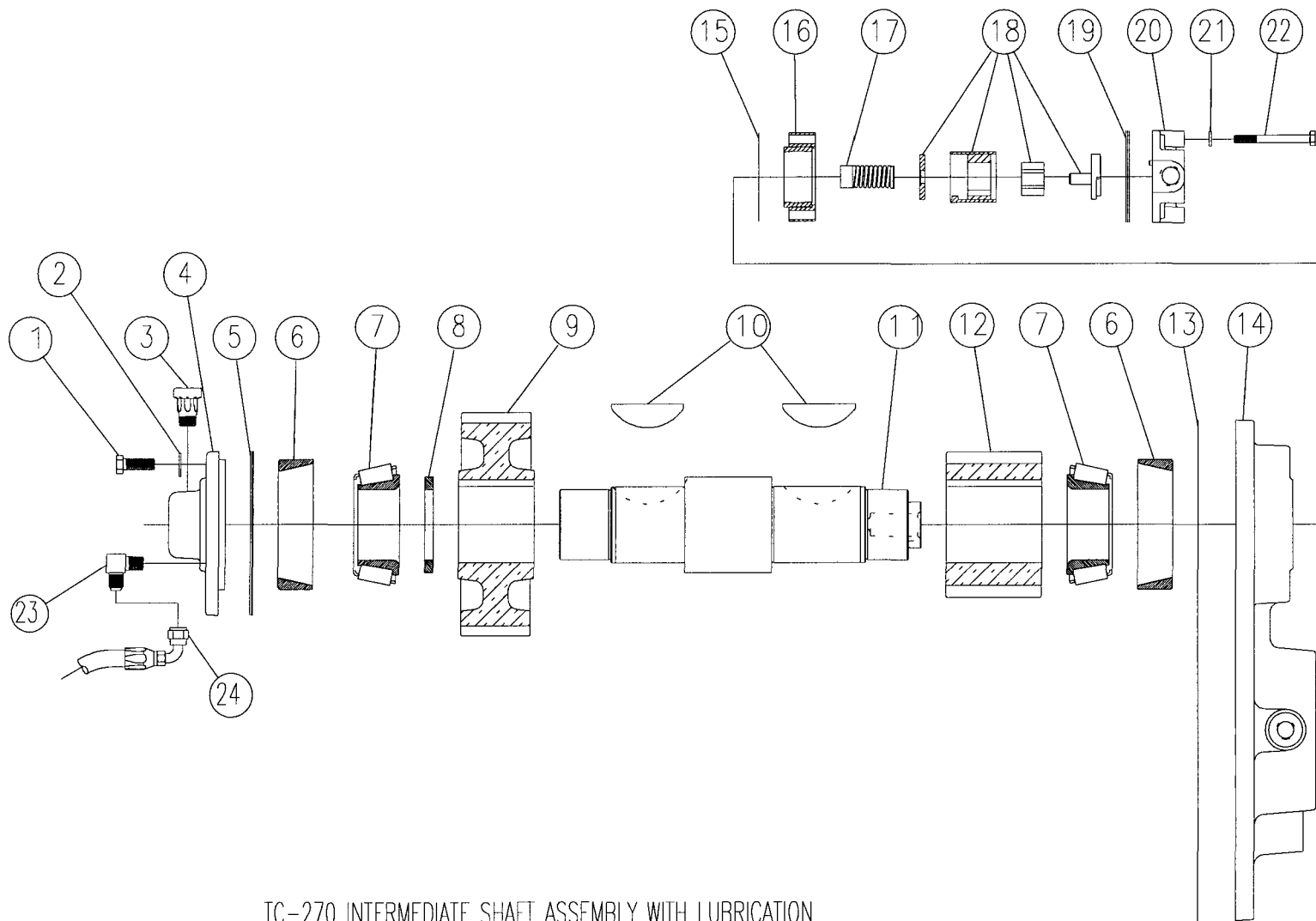

TC-270 INTERMEDIATE SHAFT ASSEMBLY WITH LUBRICATION

**TC-270 INTERMEDIATE SHAFT ASSEMBLY**  
**Models with Lubrication**

<u>ITEM</u>	<u>PART NO.</u>	<u>DESCRIPTION</u>	<u>QTY.</u>	<u>FOOT NOTE</u>	<u>ITEM</u>	<u>PART NO.</u>	<u>DESCRIPTION</u>	<u>QTY.</u>	<u>FOOT NOTE</u>
1	265 238	Bolt, 7/16-14 x 1 1/4 Hex Head	6		13	427 542	Gasket	1	
2	927 347	Washer, 7/16 Flat	6		14	237 635	Carrier, Rear	1	
3	836 223	Breather	1		15	427 468	Gasket	1	
4	235 572 003	Cap, Intermediate Front	1		16	7561324	Spacer Ring & Bearing Assembly	1	
5	744 356 001	Shim, .002 Thick, Red	A/R	1	17	777 536	Spring, Lubrication Pump, Pressure	1	
	744 356 002	Shim, .005 Thick, Blue	A/R	1					
	744 356 003	Shim, .015 Thick, Pink	A/R	1					
	744 356 004	Shim, .030 Thick, Coral	A/R	1	18	786 296	Lubrication Pump Cartridge Assembly	1	
6	233 586	Bearing Cup	2						
7	233 587	Bearing Cone	2		19	744 324	Shim, Lubrication Pump	A/R	2
8	927 842	Washer, Spacer	1		20	235 492	Cap, Lubrication Pump	1	
9	432 629	Gear, Intermediate Direct	1		21	927 299	Washer, 5/16 Lock	6	
10	966 326	Key	2		22	283 245	Bolt, Hex Head, 5/16-18 x 3	6	
11	776 326	Shaft, Intermediate	1		23	357 898	Elbow, 90°	1	
12	432 695	Gear, Intermediate Underdrive	1		24	469 822 050	Hose Assembly	1	

Footnotes:

1. See section 6.3 of service manual for adjustment procedures.
2. See section 6.7 of service manual for adjustment procedures.

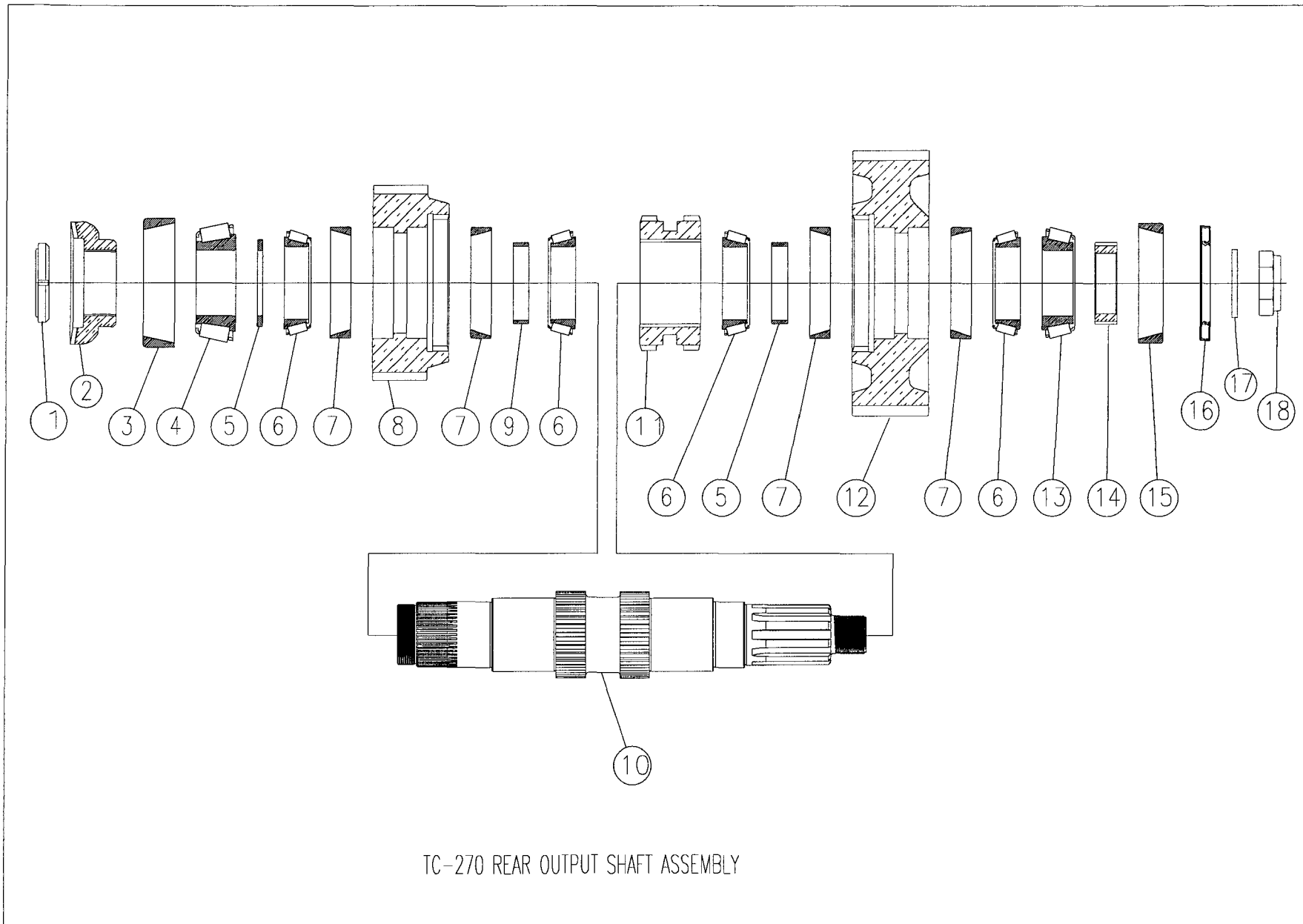

TC-270 REAR OUTPUT SHAFT ASSEMBLY

**TC-270 REAR OUTPUT SHAFT ASSEMBLY**

<u>ITEM</u>	<u>PART NO.</u>	<u>DESCRIPTION</u>	<u>QTY.</u>	<u>FOOT NOTE</u>
1	688 744	Nut, 2.751-18, Bearing Lock	1	
2	432 688	Gear, Front Declutch Fixed	1	
3	233 554	Bearing Cup	1	
4	233 556	Bearing Cone	1	
5	927 843	Washer	1	
6	233 528	Bearing Cone	4	
7	233 527	Bearing Cup	4	
8	432 659	Gear, Lower Direct Drive	1	
9	756 237 001	Ring, Bearing Spacer, .719 Thick		1
	756 237 002	Ring, Bearing Spacer, .716 Thick		1
	756 237 003	Ring, Bearing Spacer, .713 Thick		1
	756 237 004	Ring, Bearing Spacer, .710 Thick		1
10	776 327	Shaft, Rear Output	1	
11	432 656	Gear, Clutch Collar	1	
12	432 658	Gear, Lower, Overdrive	1	
13	233 497	Bearing Cone	1	
14	432 696	Gear, Electronic Speedo Sensor	1	
15	233 375	Bearing Cup	1	
16	732 428	Seal, Rear Output	1	
17	927 775 006	Washer, Output Shift	1	
18	688 642	Nut, 1 3/4-16 Lock	1	

Footnotes:

1. Select one spacer ring. See section 6.4 of service manual for adjustment procedures.

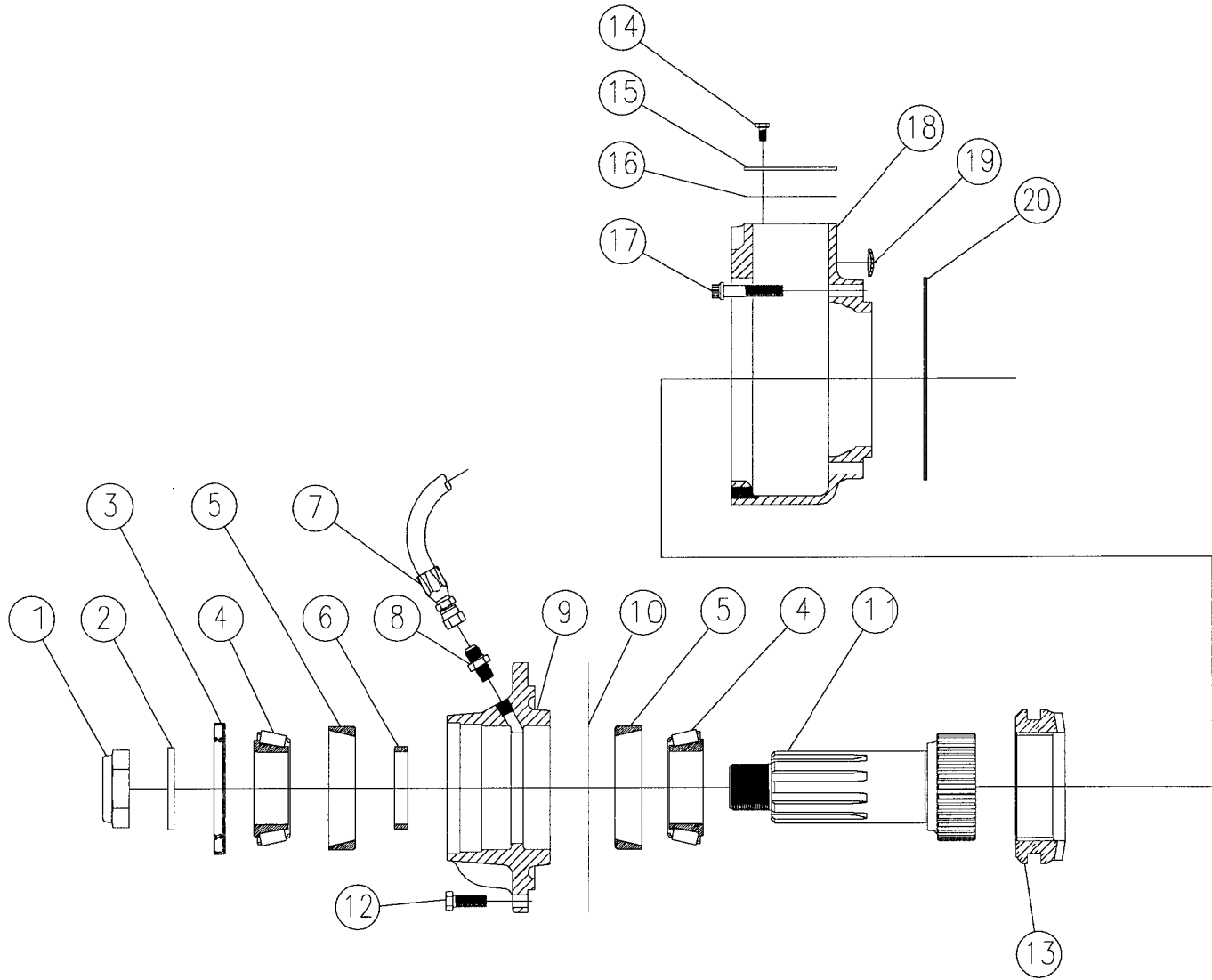

TC-270 FRONT OUTPUT SHAFT ASSEMBLY

**TC-270 FRONT OUTPUT SHAFT ASSEMBLY**  
**Models with Declutch**

<u>ITEM</u>	<u>PART NO.</u>	<u>DESCRIPTION</u>	<u>QTY.</u>	<u>FOOT NOTE</u>	<u>ITEM</u>	<u>PART NO.</u>	<u>DESCRIPTION</u>	<u>QTY.</u>	<u>FOOT NOTE</u>
1	688 642	Locknut, 1 3/4-16, Lock	1		11	776 287	Shaft, Front Output	1	
2	927 775 006	Washer, Output	1		12	265 238	Bolt, 7/16-14 x 1 1/4 Hex Head	8	
3	732 333	Seal	1		13	432 689	Gear, Front Declutch Sliding	1	
4	233 572	Bearing Cone	2		14	265 343	Bolt, 1/4-20 x 1/2 Hex Head	4	
5	233 569	Bearing Cup	2		15	792 866	Plate	1	
6	765 287 001	Ring, Bearing Spacer, .540 Thick		1	16	427 376	Gasket	1	
	765 287 002	Ring, Bearing Spacer, .545 Thick		1	17	724 677	Screw, 7/16-14 x 2 1/4, 12 Pt.	6	
	765 287 003	Ring, Bearing Spacer, .550 Thick		1	18	478 267	Housing, Declutch	1	
	765 287 004	Ring, Bearing Spacer, .555 Thick		1	19	788 328	Plug, 1" Welch	1	
7	469 882 050	Hose Assembly	1		20	744 357 001	Shim, .002 Thick, Red	A/R	2
8	357 287	Adapter	1			744 357 002	Shim, .005 Thick, Blue	A/R	2
9	237 622 002	Carrier, Front Output	1			744 357 003	Shim, .015 Thick, Pink	A/R	2
10	427 375	Gasket	1			744 357 004	Shim, .030 Thick, Coral	A/R	2

Footnotes:

1. Select one spacer ring. See Section 6.5 of Service Manual for adjustment procedures.
2. See Section 6.5 of Service Manual for adjustment procedures.

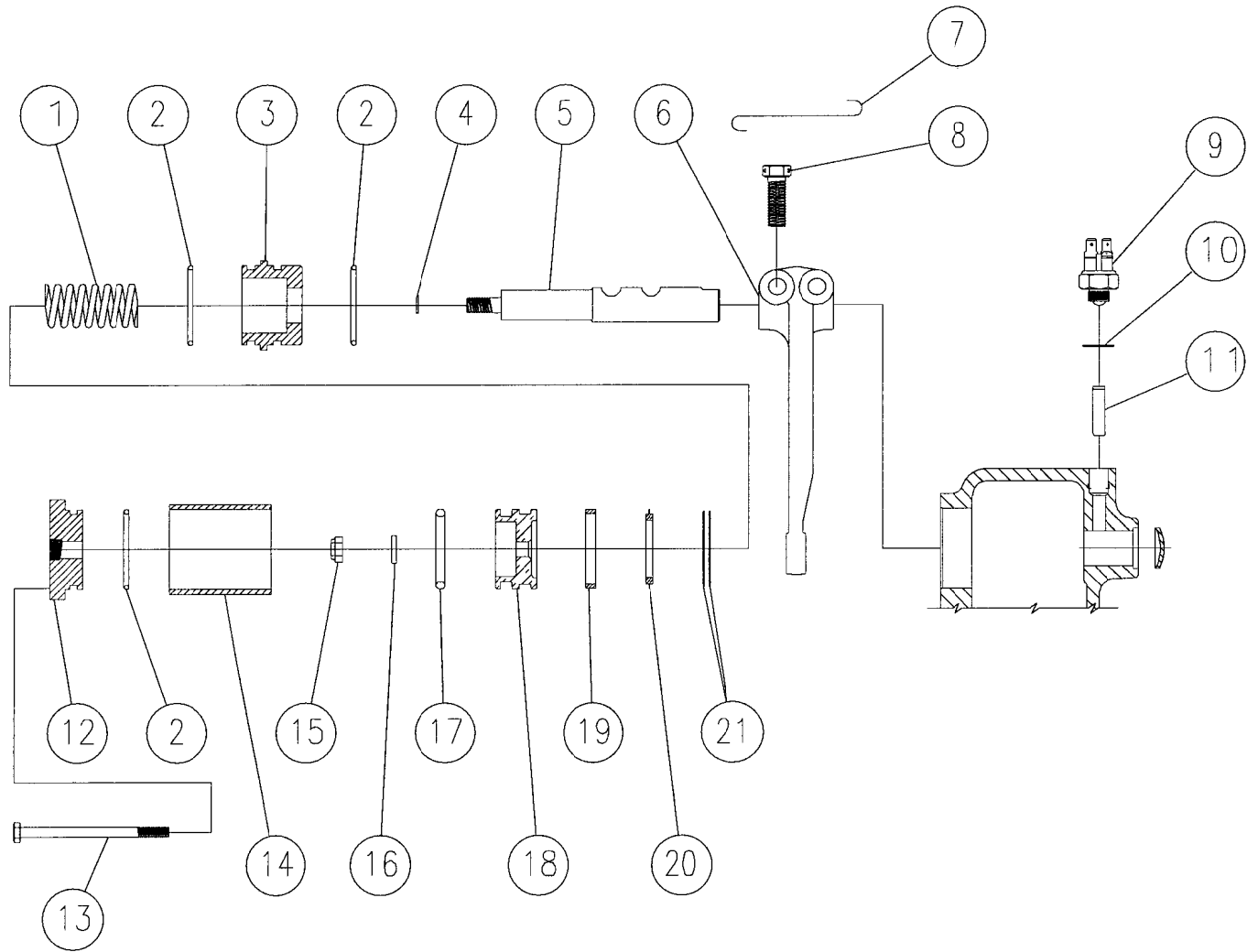

TC-270 FRONT DECLUTCH AIR SHIFT ASSEMBLY

**TC-270 FRONT DECLUTCH AIR SHIFT ASSEMBLY**

<u>ITEM</u>	<u>PART NO.</u>	<u>DESCRIPTION</u>	<u>QTY.</u>	<u>FOOT NOTE</u>
1	777 477	Spring, Front Drive Shift	1	
2	675 224	O-Ring, Piston	3	
3	883 482	Tube, Front Drive Shift Cylinder Adapter	1	
4	782 288	O-Ring	1	
5	776 296	Shaft, Front Drive Shift	1	
6	367 254	Fork, Front Declutch Shift	1	
7	947 223	Lockwire	1	
8	265 768	Bolt, 7/16-20 x 1 3/8, Drilled, Grade 8	2	
9	798 245	Switch, Shift Indicator	1	
10	927 427	Washer, Copper	1	
11	746 628	Pin, 5/16 Diameter	1	
12	235 352	Cap, Front Drive Shift Cylinder	1	
13	265 769	Bolt, 1/4-20 x 3 3/4 Hex Head	4	
14	883 887 017	Tube, Front Drive Shift Cylinder	1	
15	688 464	Nut, 3/8-24 Lock	1	
16	927 643	Washer	1	
17	675 326	O-Ring	1	
18	753 232	Piston, Front Drive Shift	1	
19	339 223	Felt Wiper	1	
20	736 747	Ring, Piston Stop	1	
21	927 822	Washer, Front Drive Shift Cylinder Adapter	A/R	1

Footnotes:

1. See Section 6.6 of service manual for adjustment procedures.

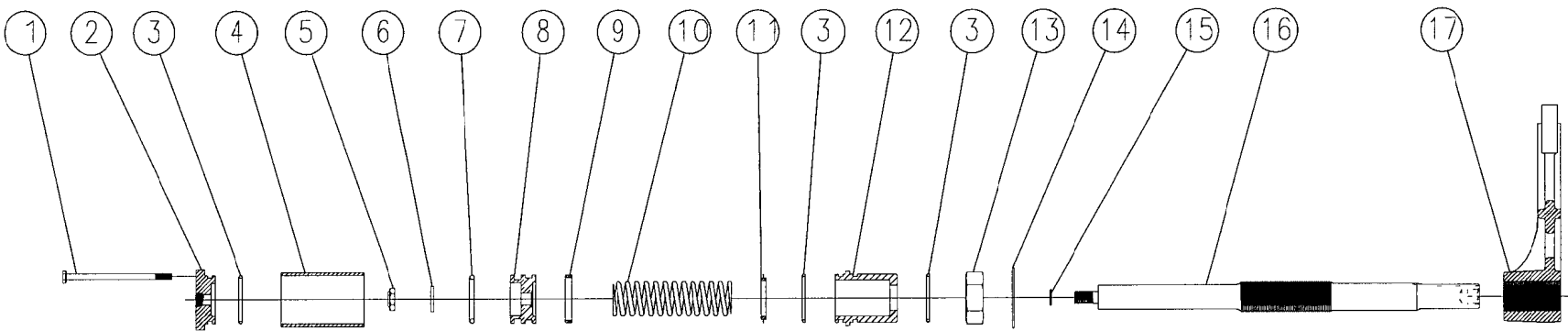

TC 270 SHIFT CYLINDER ASSEMBLY WITHOUT NEUTRAL

**TC-270 SHIFT CYLINDER ASSEMBLY**  
**Models without Neutral**

<u>ITEM</u>	<u>PART NO.</u>	<u>DESCRIPTION</u>	<u>QTY.</u>
1	265 772	Bolt, 1/4-20 x 4 1/2 Hex Head	4
2	235 528	Cap, H-L Shift Cylinder	1
3	675 224	O-Ring	3
4	883 887 005	Tube, H-L Shift Cylinder	1
5	688 725	Nut, 1/2-13, Lock	1
6	927 553	Washer, H-L Shift Shaft	1
7	675 326	O-Ring, Piston	1
8	753 245	Piston, H-L Shift	1
9	339 223	Felt Wiper	1
10	777 486	Spring, H-L Shift	1
11	736 747	Ring, Piston Stop	1
12	883 683	Tube, H-L Shift Cylinder Adapter	1
13	688 245	Nut, 1 1/4-12, Jam	1
14	793 464	Plate, Shift Fort Nut, Locking	1
15	675 014	O-Ring	1
16	776 328	Shaft, H-L Shift	1
17	367 288	Fork, H-L Shift	1

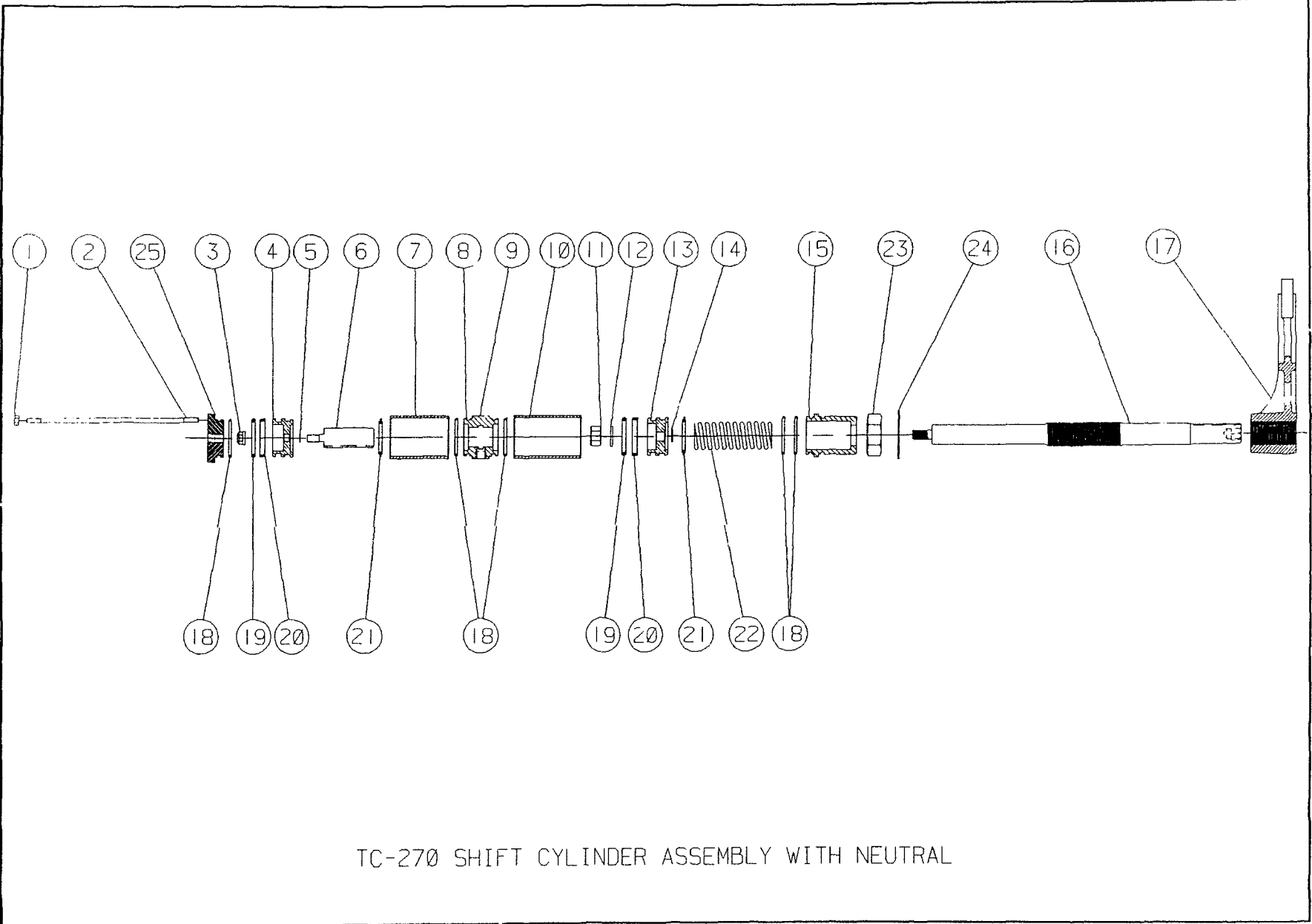

TC-270 SHIFT CYLINDER ASSEMBLY WITH NEUTRAL

**TC-270 SHIFT CYLINDER ASSEMBLY**  
**Models with Neutral**

<u>ITEM</u>	<u>PART NO.</u>	<u>DESCRIPTION</u>	<u>QTY.</u>
1	688 395	Nut, 1/4-20, Hex	1
2	788 546 002	Stud, 1/4-20 x 9"	4
3	688 464	Nut, 3/8-24, Flexlock	1
4	753 232	Piston, Neutral Shift	1
5	782 288	O-Ring	1
6	769 389	Shaft, Neutral Shift	1
7	883 887 006	Tube, Neutral Shift	1
8	927 643	Washer	1
9	883 893	Tube, Neutral Shift Adapter	1
10	883 887 005	Tube, H-L Shift Cylinder	1
11	688 726	Nut. 1/2-13, Lock	1
12	927 553	Washer	1
13	753 245	Piston, H-t Shift	1
14	675 014	O-Ring	1
15	883 683	Tube, H-L Shift Cylinder Adapter	1
16	776 328	Shaft, H-L Shift	1
17	367 288	Fork, Shift	1
18	675 324	O-Ring, Adapters & Caps	5
19	675 326	O-Ring	2
20	339 223	Felt Wiper	2
21	736 747	Ring, Piston Stop	2
22	777 486	Spring, H-L Shift	1
23	688 245	Nut, 1 1/4-12 Jam	1
24	793 464	Plate, Shift Fork Nut, Locking	1
25	235 352	Cap, Shift Cylinder	1

**TC-270 PARTS NOT ILLUSTRATED**

<u>ITEM</u>	<u>PART NO.</u>	<u>DESCRIPTION</u>	<u>QTY.</u>	<u>FOOT NOTE</u>
1	273 764	Filter Mounting Bracket	1	1
2	345 267	Filter, Oil	1	1
3	345 268	Strainer, Oil	1	1
4	478 288	Housing, Transfer Case Main	1	
5	737 551 001	Lubrication Piping Kit For assembly no. 873 044 003 and 873 044 006 (basic case with <u>no</u> provisions for field installation of PTO).		
	737 551 002	Lubrication Piping Kit For assembly no. 873 044 004 (model with PTO).		
	737 551 004	Lubrication Piping Kit For assembly no. 873 044 007 (basic case <u>with</u> provisions for field installation of PTO).		
6	758 232	Plug, 1/4 NPT		
7	758 274	Plug, 3/4 NPT Magnetic, Oil Drive		
8	758 352	Plug, 3/4 NPT Oil Fill		

Footnotes:

1. Part is included in lubrication piping kit.